

**IMPERIAL COMMUNITY COLLEGE DISTRICT
PROJECT: BUILDING 700 – TRANSFORMER UPGRADE**

Request for Proposals No. 20-21-21

TABLE OF CONTENTS

Section Number	Description
00 01 13	Notice to Contractors
00 21 13	Instructions for Bidders
00 41 00	Bid Proposal
00 43 13	Subcontractors List
00 43 15	Qualifications Statement
00 45 19	Non-Collusion Affidavit
00 45 26	Certificate of Worker's Compensation
00 45 27	Drug Free Workplace Certification
00 52 00	Contract for Labor and Materials; Contract Terms and Conditions
00 61 00	Bid Bond
00 61 13	Performance Bond
00 61 14	Labor & Materials Payment Bond
00 62 90	Verification of Certified Payroll Records Submittal to Labor Commissioner
00 62 91	Contractor Certification of Subcontractor Claim
	Special Provisions

NOTICE TO CONTRACTORS**REQUEST FOR BIDS: BID NO. 20-21-21****PROJECT: BUILDING 700 – TRANSFORMER UPGRADE**

PLEASE TAKE NOTICE, that the District will accept Bid Proposals under the District's CUPCCAA Formal Bidding procedures pursuant to Public Contract Code § 22037 for the Work of a Project described as **BUILDING 700 – TRANSFORMER UPGRADE**

1. Project Information. Additional information regarding the Project, including Drawings, Specifications are available at <https://www.imperial.edu/about/request-for-proposals/> or at Rocket Copy, 100 S. 11th St., El Centro, CA 92243.
 2. Contractors' License. The District requires that Bidders possess the following classification(s) of California Contractors License at the time the Bid Proposal is submitted and at time that the Contract for the Work is awarded: B - General Building Contractor; or C-10 Electrical;. The Bid Proposal of a Bidder who does not possess a valid and in good standing Contractors' License in the classification(s) set forth above will be rejected for non-responsiveness.
 3. Labor Code. The Bidder and all Subcontractors must be DIR Registered Contractors at the time of submitting the Bid Proposal. The Work is subject to prevailing wage rates and other applicable Labor Code requirements; the Contractor and all Subcontractors shall pay not less than the prevailing wage rates for the classification(s) of labor necessary to complete the Work and comply with all applicable Labor Code requirements.
 4. Contract Time and Liquidated Damages. The Contract Time for completing the Project is set forth in the Agreement. Liquidated Damages set forth in the Agreement will be assessed for failure to complete the Project within the Contract Time.
 5. Submittal of Bid Proposals. Bid Proposals for the Work must be submitted in a sealed envelope, with the Bidder's name and the Project prominently identified on the cover of such envelope to the District as follows:

Imperial Community College District
Attn: Javier Luna, Director of Facilities, Planning, and Construction
380 E. Aten Road
Building 10, Room #16
Imperial, CA 92251
- Bid Proposals must be received by the District's Bond Management Department, no later than **2:00 PM Wednesday, July 28, 2021**. Bid Proposals submitted thereafter will be rejected for non-responsiveness. Timely submitted Bid Proposals will be opened as soon thereafter as practicable.
6. Mandatory Job Walk. The District will conduct a Mandatory Job Walk beginning at **10 AM on Wednesday, July 07, 2021**. Bidders are to meet at the Building 2000 for the Job Walk.
 7. Documents Accompanying Bid Proposal. The following must be submitted with the Bid Proposal; failure to submit all of the following will result in rejection of the Bid Proposal for non-responsiveness:
 - (i) Subcontractors List (00 43 13) identifying each Subcontractor performing a portion of the Work valued at or greater than one-half of one percent of the price proposed in the Bid Proposal);
 - (ii) Non-Collusion Affidavit (00 45 19);
 - (iii) Bid Security of not less than ten percent (10%) of the price proposed in the Bid Proposal in the form of cash, cashiers/certified check payable to the District or a Bid Bond in the form and content included with the Contract Documents (00 61 00);
 - (iv) Certificate of Workers Compensation Insurance in the form and content included with the Contract Documents (00 45 26);
 - (v) Drug-Free Workplace Certification in the form and content included with the Contract Documents (00 45 27).
 8. Award of Contract. The Contract for the Work, if awarded will be by action of the District's Board of Trustees, to the responsible Bidder submitting the lowest priced responsive Bid Proposal.
 9. Performance Bond; Labor and Materials Payment Bond. The Bidder awarded the Contract for the Work shall obtain a Performance Bond and a Labor and Materials Payment Bond, each in a penal sum equal to one hundred percent (100%) of the Contract Price of the Contract awarded in the form and content included with the Contract Documents for the Project.
 10. Rejection of Bid Proposals; Waiver of Minor Irregularities. The District expressly reserves the right to reject all Bid Proposals or to waive minor irregularities in the bidding process or in Bid Proposals submitted in response hereto.

Advertisement/Notice Dates:

Newspaper Advertisement
Trade Journals Notice

Friday, June 25, 2021
Friday, July 2, 2021

[END OF SECTION]

INSTRUCTIONS FOR BIDDERS

1. Preparation and Submittal of Bid Proposal. All information required by the bid forms must be completely and accurately provided. Numbers shall be stated in both words and figures where required in the bid forms; conflicts between a number stated in words and in figures are governed by the words. Partially completed Bid Proposals or Bid Proposals submitted on other than the bid forms included herein are non-responsive and will be rejected. Any document submitted with a Bid Proposal which is not complete, accurate and executed, as required by each document, will result in the Bid Proposal being deemed non-responsive. All Bid Proposals be submitted before the latest date/time for submitting Bid Proposals (See Notice to Contractors). Bidders are solely responsible for timely submission of Bid Proposals to the District at the place designated in the Notice to Contractors.
2. Bid Security. Each Bid Proposal shall be accompanied by Bid Security in the form of: (i) cash, (ii) a certified or cashier's check made payable to the District or (iii) a Bid Bond, in the form and content included with the Contract Documents in an amount equal to Ten Percent (10%) of the Bid Proposal amount, inclusive of the price(s) proposed for additive Alternate Bid Items, if any. A Bid Proposal submitted without the required Bid Security is non-responsive and will be rejected. If the Bid Security is a Bid Bond, the Bidder's Bid Proposal shall be deemed responsive only if the Bid Bond is issued by an Admitted Surety Insurer under Code of Civil Procedure §995.120 in the form and content included herein, duly completed and executed (with notary acknowledgements) on behalf of the Bidder and Surety. Bid Security shall be submitted as set forth in Paragraph 5 of the Call for Bids.
3. Bidder Modifications; Withdrawal or Modification of Submitted Bid Proposal.
 - 3.1. Erasures; Inconsistent or Illegible Bid Proposals. Bid Proposals must not contain any erasures, interlineations or other corrections unless the same are suitably authenticated by affixing in the margin immediately opposite such erasure, interlineations or correction the initials or surname(s) of the person(s) signing the Bid Proposal. Any Bid Proposal not conforming with the foregoing may be deemed by the District to be non-responsive. If any Bid Proposal or portions thereof, is determined by the District to be illegible, ambiguous or inconsistent, the District may reject such a Bid Proposal as being non-responsive.
 - 3.2. Withdrawal or Modification of Submitted Bid Proposal. Bid Proposals may be withdrawn or modified only if: (i) the Bidder submitting the Bid Proposal submits a written request for withdrawal or modification to the District; and (ii) the written withdrawal or modification request is actually received by the District prior to the latest date/time for submittal of Bid Proposals. Requests for withdrawal of a Bid Proposal after the public opening of Bid Proposals pursuant to Public Contract Code §5100 et seq. will be considered only if in strict conformity with requirements of Public Contract Code §5100 et seq.
4. Examination of Site and Contract Documents. Each Bidder shall, at its sole cost and expense, inspect the Site and to become fully acquainted with the Contract Documents and conditions affecting the Work. The failure of a Bidder to receive or examine any of the Contract Documents or to inspect the Site shall not relieve such Bidder from any obligation with respect to the Bid Proposal, or the Work required under the Contract Documents. The District assumes no responsibility or liability to any Bidder for, nor shall the District be bound by, any understandings, representations or agreements of the District's representatives, agents, employees or officers concerning the Contract Documents or the Work made prior to execution of the Contract which are not in the form of Bid Addenda duly issued by the District. The submission of a Bid Proposal shall be deemed prima facie evidence of the Bidder's full compliance with the requirements of this section.
5. Agreement and Bonds. The Agreement which the successful Bidder, as Contractor, will be required to execute along with the forms for the Labor and Material Payment Bond, Performance Bond and other documents and instruments which will be required to be furnished by the successful are

included or described in the Contract Documents and shall be carefully examined by the Bidder. The required number of executed copies of the Agreement and the form and content of the Performance Bond, the Labor and Material Payment Bond, Subcontractor Performance Bond and other documents or instruments required at the time of execution of the Agreement are specified in the Contract Documents.

6. Pre-Bid Questions; Contract Document Interpretation and Modifications.

6.1. Bidder Pre-Bid Questions. Any Bidder in doubt as to the true meaning of any part of the Contract Documents, finds discrepancies, errors or omissions therein, or finds variances in any of the Contract Documents with the Laws ("Pre-Bid Questions"), shall submit electronically to the District by email to: construction-facilities@imperial.edu. Bidders are solely and exclusively responsible for submitting Pre-Bid Questions no later than the time/date designated in the Notice to Bidders Bid Schedule (Addendum 1). Responses to Pre-Bid Questions will be by addendum issued by, or on behalf of, the District. Addendum will be posted on the District's Website. Failure to request interpretation or clarification of any portion of the Contract Documents pursuant to the foregoing is a waiver of any discrepancy, defect or conflict therein.

6.2. No Oral Interpretations. No person is authorized to: (i) render an oral interpretation or correction of any portion of the Contract Documents; or (ii) provide oral responses to Pre-Bid Questions. No Bidder is authorized to rely on any such oral interpretation, correction or response.

6.3. District's Right to Modify Contract Documents. Before the public opening and reading of Bid Proposals, the District may modify the Work, the Contract Documents, or any portion(s) thereof by the issuance of written addenda. If the District issues any addenda during the bidding, the failure of any Bidder to acknowledge such addenda in its Bid Proposal will render the Bid Proposal non-responsive and rejected.

6.4. Bidder's Assumptions. The District is not responsible for any assumptions made or used by the Bidder in calculating its Bid Proposal Amount including, without limitation, assumptions regarding costs of labor, materials, equipment or substitutions/alternatives for any material, equipment, product, item or system incorporated into or forming a part of the Work which have not been previously expressly approved and accepted by the District. The successful Bidder, upon award of the Contract by the District, if any, will be required to complete the Work for the amount bid in the Bid Proposal within the Contract Time and in accordance with the Contract Documents.

7. Award of Contract.

7.1. Waiver of Irregularities or Informalities. The District reserves the right to reject any and all Bid Proposals or to waive any irregularities or informalities in any Bid Proposal or in the bidding.

7.2. Award to Responsible Bidder Submitting Lowest Priced Responsive Bid Proposal. The award of the Contract, if made by the District through action of its Board of Trustees, will be to the responsible Bidder submitting the lowest priced responsive Bid Proposal.

7.3. Award of Contract. If the Bidder submitting this Bid Proposal is awarded the Contract, the Bidder will execute and deliver to the District the Agreement in the form attached hereto within Three (3) calendar days after notification of award of the Contract. Concurrently with delivery of the executed Agreement to the District, the Bidder awarded the Contract shall deliver to the District:

- Agreement
- Certificates of Insurance evidencing all insurance coverages the Bidder and its Subcontractors are required to obtain under the Contract Documents
- Labor and Material Payment Bond
- Performance Bond
- Certificate of Workers' Compensation Insurance
- Drug-Free Workplace Certificate

Failure of the Bidder awarded the Contract to strictly comply with the preceding may result in the District's rescinding award of the Contract and/or forfeiture of the Bidder's Bid Security. In such event, the District may, in its sole and exclusive discretion elect to award the Contract to the responsible Bidder submitting the next lowest priced Bid Proposal or to reject all Bid Proposals.

7.4. Responsive Bid Proposal. A responsive Bid Proposal means a Bid Proposal which conforms, in all material respects, to the Bid and Contract Documents. A Bid Proposal which does not conform to material bidding requirements, as reasonably determined by the District, is subject to rejection for non-responsiveness.

7.5. Responsible Bidder.

7.5.1. Bidder Capacity. Factors affecting the Bidder's capacity to perform and complete the Work will be assessed, including: (i) Bidder's access to labor, materials and other resources necessary to complete the Work; (ii) Bidder's ability to complete the Work within the time established for completion of the Work, or portions thereof; and (iii) Bidder's ability to complete warranty obligations.

7.5.2. Bidder Character, Integrity. Factors reflecting the character and integrity of the Bidder, including: (i) other public agency finding/determination, within the past five (5) years, that the Bidder is not responsible; (ii) currently debarred from bidding public works projects or debarment from bidding within past five (5) years; and (iii) false claims liability within the past five (5) years under local, state or federal laws.

7.5.3. Bidder Financial Capability. Factors considered include: (i) sufficiency of the Bidder's financial resources; (ii) whether the Bidder is current in payment of debts and performance of other financial obligations; and (iii) bankruptcy or insolvency proceedings have been instituted within the past five (5) years.

7.5.4. Bidder Prior Performance. The Bidder's prior performance on prior public works contracts, including without limitation: (i) cost overruns; (ii) compliance with general conditions and other contractual requirements, including schedule development, schedule updates and coordination of labor, material/equipment procurements and subcontractors; (iii) completion within allocated time; (iv) submittal of unsubstantiated, unsupported or excessive cost proposals, claims or contract adjustment requests; (v) completion of a project by a surety; (vi) owner's exercise of default remedies; and (vii) finding or determination by any public agency that the Bidder is not a responsible bidder.

7.5.5. Safety. Factors include: (i) findings of serious or willful safety violations of safety laws, regulations or requirements by any local, state or federal agency within the past five (5) years; (ii) adequacy and implementation of safety plans, programs for on-site and off-site construction and construction related activities; and (iii) Workers Compensation Insurance EMR rating exceeding 1.25.

8. Subcontractors: Subcontractors List. Each Bidder shall identify its proposed Subcontractors for the proposed Work, including any Alternate Bid Items, who will perform/provide portions of the Work valued at or more than one-half (1/2) of one percent (1%) of the amount proposed by the Bidder for the Work. The Bidder's proposed Subcontractors shall be identified in the form of Subcontractors List. The Subcontractors List requires the Bidder's disclosure of information relating to each listed Subcontractor as follows:

Name of Subcontractor
 Subcontractor's Address
 Subcontractor's Portion of the Work
 Subcontractor's California Contractors' License
 Subcontractor DIR Registration

Failure of a Bidder to provide all required information for all listed Subcontractors will result in rejection of the Bidder's Bid Proposal for non-responsiveness. All Bidders are referred to the Contract Documents and the notation therein that all Contract Documents are intended to be complimentary and that the organization or arrangements of the Specifications and Drawings shall not limit the extent of the Work of the Contract Documents. The omission of any portion or item of Work from the Bid Proposal or from the sub-bidders' sub-bids which is/are necessary to produce the intended results and/or which are reasonably inferable from the Contract Documents is not a basis for adjustment of the Contract Price or the Contract Time. Dissemination of the Contract Documents to sub-bidders and dissemination of addenda issued during the bidding process is solely the responsibility of each Bidder.

9. Workers' Compensation Insurance. Pursuant to California Labor Code §3700, the successful Bidder shall secure Workers' Compensation Insurance for its employees engaged in the Work of the Contract. The successful Bidder shall execute and deliver to the District the form of Workers Compensation Certification included in the Contract Documents concurrently with such Bidder's delivery of the executed Agreement to the District.
10. Bid Security Return. The Bid Security of the four (4) Bidders submitting the four (4) lowest priced responsive Bid Proposals, will be held by the District for ten (10) calendar days after the period for which Bid Proposals must be held open (which is set forth in the Call for Bids) or until posting by the successful Bidder(s) of the bonds, certificates of insurance required and return of executed copies of the Agreement, whichever occurs later, at which time the Bid Security of such other Bidders will be returned to them.
11. Forfeiture of Bid Security. If the Bidder awarded the Contract fails or refuses to execute the Agreement within time set forth in the Bid Proposal, the District may declare the Bidder's Bid Security forfeited as damages caused by the failure of the Bidder to enter into the Contract and may thereupon award the Contract for the Work to the responsible Bidder submitting the next lowest priced Bid Proposal or may call for new bids, in its sole and exclusive discretion.
12. Contractors' License. No Bid Proposal will be considered from a Bidder who, at the time Bid Proposals are opened, is not licensed to perform the Work, in accordance with the Contractors' License Law, California Business & Professions Code §§7000 et seq. This requirement is not a mere formality and will not be waived by the District or its Board of Trustees. The required California Contractors' License classification(s) for the Work is set forth in the Call for Bids.
13. Bidder's Qualifications. Each Bidder shall submit with its Bid Proposal the form of Qualifications Statement, which is included within the Contract Documents. All information required by the Qualifications Statement shall be completely and fully provided. Any Bid Proposal not accompanied by the Qualifications Statement completed with all information required and bearing the signature of the Bidder's duly authorized representative under penalty of perjury will render the Bid Proposal non-responsive and rejected. If the District determines that any information provided by a Bidder in the Qualifications Statement is false or misleading or is incomplete so as to be false or misleading, the District may reject the Bid Proposal submitted by such Bidder as being non-responsive. If any response to the "Essential Requirements" section of the Qualifications Statement is a "not qualified" response, the Bidder's Bid Proposal will be rejected for failure of the Bidder to meet minimum qualifications for the Work.
14. Job-Walk. The District will conduct a Job-Walk at the time(s) and place(s) designated in the Call for Bids. If attendance at the Job Walk is indicated in the Call for Bids as being mandatory, the failure of any Bidder to have its authorized representative present at the entirety of the Job-Walk will render the Bid Proposal of such Bidder to be non-responsive.
15. Public Records. Bid Proposals and other documents responding to the Call for Bids become the exclusive property of the District upon submittal to the District. At such time as the District issues

the Notice of Intent to award the Contract pursuant to these Instructions for Bidders, all Bid Proposals and other documents submitted in response to the Call for Bids become a matter of public record and shall be thereupon be considered public records, except for information contained in such Bid Proposals deemed to be Trade Secrets (as defined in California Civil Code §3426.1) and information provided in response to the Qualifications Statement. A Bidder that indiscriminately marks all or most of its Bid Proposal as exempt from disclosure as a public record, whether by the notations of "Trade Secret," "Confidential," "Proprietary," or other similar notations, may result in, or render, the Bid Proposal non-responsive and rejected. The District is not liable or responsible for the disclosure of such records, including those exempt from disclosure if disclosure is deemed required by law, by an order of Court, or which occurs through inadvertence, mistake or negligence on the part of the District or its officers, employees or agents. At such time as Bid Proposals are deemed a matter of public record, pursuant to the above, any Bidder or other party shall be afforded access for inspection and/or copying of such Bid Proposals, by request made to the District in conformity with the California Access to Public Records Act, California Government Code §§6250, et. seq. If the District is required to defend or otherwise respond to any action or proceeding wherein request is made for the disclosure of the contents of any portion of a Bid Proposal deemed exempt from disclosure hereunder, the Bidder submitting the materials sought by such action or proceeding agrees to defend, indemnify and hold harmless the District in any action or proceeding from and against any liability, including without limitation attorneys' fees arising therefrom. The party submitting materials sought by any other party shall be solely responsible for the cost and defense in any action or proceeding seeking to compel disclosure of such materials; the District's sole involvement in any such action shall be that of a stakeholder, retaining the requested materials until otherwise ordered by a court of competent jurisdiction.

16. Notice of Intent to Award Contract. Following the public opening and reading of Bid Proposals, the District will issue a Notice of Intent to Award the Contract, identifying the Bidder to whom the District intends to award the Contract and the date/time/place of the District's Board of Trustees meeting at which award of the Contract will be considered.

17. Bid Protest.

17.1. Submittal of Bid Protest. Any Bidder submitting a Bid Proposal to the District may file a protest of the District's intent to award the Contract provided that all of the following are complied with: (i) the bid protest is in writing; (ii) the bid protest is filed and received by the District's Vice President, Administrative Services ("Vice President") not more than five (5) calendar days after the date of issuance of the District's Notice of Intent to Award the Contract; and (iii) the written bid protest sets forth, in detail, all grounds for the bid protest, including without limitation all facts, supporting documentation, legal authorities and argument in support of the grounds for the bid protest; any matters not set forth in the written bid protest shall be deemed waived. All factual contentions must be supported by competent, admissible and creditable evidence. Any bid protest not conforming to the foregoing shall be rejected by the District as invalid.

17.2. District Review and Disposition of Bid Protest. Provided that a bid protest is filed in strict conformity with the foregoing, the Vice President or such individual(s) as may be designated by him/her ("Designee") will review and evaluate the basis of the bid protest. The Vice President or Designee shall provide the Bidder submitting the bid protest with a written statement concurring with or denying the bid protest ("Bid Protest Response"). The Bid Protest Response is deemed the final action of the District and not subject to appeal or reconsideration by any other employee or officer of the District or the Board of Trustees of the District. The issuance of the Bid Protest Response by the Vice President or the Designee is an express condition precedent to the institution of any legal or equitable proceedings relative to the bidding process, the District's intent to award the Contract, the District's disposition of any bid protest or the District's decision to reject all Bid Proposals. If any such

legal or equitable proceedings are instituted and the District is named as a party thereto, the prevailing party(ies) shall recover from the other party(ies), as costs, all attorneys' fees and costs incurred in connection with any such proceeding, including any appeal arising therefrom. Each Bidder shall acknowledge in the Bid Proposal that the foregoing is a binding attorneys' fee agreement pursuant to Civil Code §1717 and shall be enforceable against the Bidder and the District.

BID PROPOSAL

PROJECT: BUILDING 700 – TRANSFORMER UPGRADE
TO: IMPERIAL COMMUNITY COLLEGE DISTRICT (“the District”).
FROM:

Bidder	_____		
	(Bidder Name)		

	(Street Address)		

(City, State, Zip Code)			

(_____) _____			
(Telephone)			
Bidder Contact Person and Email	_____		
	(Name)		

(Email Address)			
Contractors' License	_____	_____	_____
	(License Number)	(Expiration Date)	(License Classifications)

DIR Registration Number	_____		

1. Bid Proposal

1.1 Bid Proposal Amount. The undersigned Bidder proposes and agrees to perform the Contract including, without limitation, providing and furnishing any and all of the labor, materials, tools, equipment and services necessary to perform the Contract and complete in a workmanlike manner all of the Work required for the Project described as: **BUILDING 700 – TRANSFORMER UPGRADE** for the sum of _____ Dollars (\$ _____). The Bidder confirms that it has checked all of the above figures and understands that neither the District nor any of its agents, employees or representatives shall be responsible for any errors or omissions on the part of the undersigned Bidder in preparing and submitting this Bid Proposal.

1.2 Acknowledgment of Bid Addenda. The Bidder confirms that this Bid Proposal incorporates and is inclusive of, all items or other matters contained in Bid Addenda issued by or on behalf of the District.

_____ **Addenda Nos.** _____ received, acknowledged
 (initial) and incorporated into this Bid Proposal.

2. Documents Accompanying Bid. The Bidder has submitted with this Bid Proposal the following:

- (i) Subcontractors List (00 43 13) identifying each Subcontractor performing a portion of the Work valued at or greater than one-half of one percent of the price proposed in the Bid Proposal);
- (ii) Non-Collusion Affidavit (00 45 19);
- (iii) Qualifications Statement (00 43 15);
- (iv) Bid Security of not less than ten percent (10%) of the price proposed in the Bid Proposal in the form of cash, certified/cashier’s check payable to the District or a

- Bid Bond in the form and content included with the Contract Documents (00 61 00);
- (v) Certificate of Workers Compensation Insurance in the form and content included with the Contract Documents (00 45 26);
- (vi) Drug-Free Workplace Certification in the form and content included with the Contract Documents (00 45 27)

The Bidder acknowledges that if this Bid Proposal and the foregoing documents are not fully in compliance with applicable requirements set forth in the Notice of Informal Bidding and Bidding Information and in each of the foregoing documents, the Bid Proposal may be rejected as non-responsive.

- 3. Award of Contract.** If the Bidder submitting this Bid Proposal is awarded the Contract, the undersigned will execute and deliver to the District the Contract for Labor and Materials in the form attached hereto within five (5) days after notification of award of the Contract. Concurrently with delivery of the executed Agreement to the District, the Bidder awarded the Contract shall deliver to the District: (a) Certificates of Insurance evidencing all insurance coverages required under the Contract Documents; (b) the Performance Bond; and (c) the Labor and Material Payment Bond. Failure of the Bidder awarded the Contract to strictly comply with the preceding may result in the District's rescission of the award of the Contract and/or forfeiture of the Bidder's Bid Security. In such event, the District may, in its sole and exclusive discretion elect to award the Contract to the responsible Bidder submitting the next lowest Bid Proposal, or to reject all Bid Proposals.
- 4. Acknowledgment and Confirmation.** The undersigned Bidder acknowledges its receipt, review and understanding of the Drawings, the Specifications and other Contract Documents pertaining to the proposed Work. The undersigned Bidder certifies that the Contract Documents are, in its opinion, adequate, feasible and complete for providing, performing and constructing the Work in a sound and suitable manner for the use specified and intended by the Contract Documents. The undersigned Bidder certifies that it has, or has available, all necessary equipment, personnel, materials, facilities and technical and financial ability to complete the Work for the amount bid herein within the Contract Time and in accordance with the Contract Documents.

By: _____
(Signature)

(Typed or Printed Name)

Title: _____

SUBCONTRACTORS LIST

Project ("the Work")	BUILDING 700 – TRANSFORMER UPGRADE
Bidder Name	_____
Bidder's Representative Signature	_____ (Signature)
	_____ (Typed or Printed Name)

Licensed Name of Subcontractor	Address of Office, Mill or Shop	Trade or Portion of Work	Contractors' License Number	DIR Registration Number

[DUPLICATE THIS FORM FOR ADDITIONAL SUBCONTRACTORS]

QUALIFICATIONS STATEMENT

Each Bidder must complete and submit this Qualifications Statement with the Bidder's Bid Proposal. The Qualifications Statement must be executed under penalty of perjury by an authorized employee or officer of the Bidder. All portions of the Qualifications Statement must be completed failure to do so will render the Bid Proposal non-responsive and rejected. If a Bidder's response to any Essential Requirement results in a "Not Qualified" response, the Bid Proposal of such a Bidder will be rejected for failure of the Bidder to meet Essential Requirements for the Project.

Bidder Name: _____

1. Insurance and Bonding.

<p>Commercial General Liability Insurance</p>	<p>Insurer: _____ Policy No.: _____ Broker: _____ Coverage Limits: Per Occurrence: _____ Dollars (\$ _____) Aggregate: _____ Dollars (\$ _____)</p>
<p>Bid, Performance and Labor & Materials Payment Bond</p>	<p>Surety: _____ Surety Broker: _____ _____ (Surety Broker Contact Name) _____ (Street Address) _____ (City, State & Zip Code) (_____) _____ (_____) _____ Telephone Fax _____ (Email address) Bonding Capacity: Maximum Per Project: _____ Dollars (\$ _____) Maximum All Projects _____ Dollars (\$ _____)</p>
<p>Workers Compensation Insurance</p>	<p>Insurer: _____ Policy No. _____ Broker: _____ Current EMR _____</p>

[CONTINUED NEXT PAGE]

2. Essential Requirements. A Bidder will not be deemed qualified and if the response to any of the following results in a “not qualified” response; the Bid Proposal of such a Bidder will be rejected for failure of the Bidder to meet Essential Requirements for the Project.

2.1 Bidder possesses a valid and currently in good standing California Contractors’ license of the trade category(ies) for the Project as set forth in the Notice to Contractors.

- Yes
- No (Not Qualified)

2.2 Bidder has a current commercial general liability insurance policy with coverage limits which meet or exceed the policy limits required for the Project.

- Yes
- No (Not Qualified)

2.3 Bidder has a current workers’ compensation insurance policy as required by the Labor Code or is legally self-insured pursuant to Labor Code §3700.

- Yes
- No (Not Qualified)
- Bidder is exempt from this requirement, because it has no employees

2.4 What is the Applicant’s maximum per project bonding capacity?

_____ Dollars (\$ _____)

2.5 What is the Applicant’s aggregate bonding capacity for all projects?

_____ Dollars (\$ _____)

2.6 A letter from the applicant’s surety or surety broker confirming the Applicant’s aggregate is attached:

- Yes
- No (Failure to attach surety or surety broker letter verifying Applicant bonding capacity will result in rejection of the Applicant’s essential requirements section for non-responsiveness)

2.7 Bidder is ineligible or debarred from submitting bid proposals for public works projects or public works contracts pursuant Labor Code §1777.1 or Labor Code §1777.7?

- Yes (Not Qualified)
- No

2.8 Within the past five (5) years a public agency has determined that the Bidder, or any predecessor to the Bidder, is not a “responsible” bidder for a public works project or a public works contract?

- Yes (Not Qualified)
- No

2.9 During the past five (5) years, the Bidder or any predecessor to the Bidder, or any of the equity owners of the Bidder been convicted of a federal or state crime involving fraud, theft, or any other act of dishonesty.

- Yes (Not Qualified)
- No

2.10 During the past five (5) years a Surety has completed any project or the Bidder’s obligations under a construction contract.

- Yes (Not Qualified)
- No

2.11 During the past five (5) years the Bidder been declared in default under a construction contract to which the Bidder was a party.

- Yes (Not Qualified)
 No

2.12 The Bidder's Worker's Compensation Insurance prior five (5) year average Experience Modification Rating ("EMR") rating over the past five (5) years is more than 1.5.

- Yes (Not Qualified)
 No

2.13 The Bidder's Worker's Compensation Insurance current average Experience Modification Rating ("EMR") rating is more than 1.5.

- Yes (Not Qualified)
 No

2.14 CAL OSHA or OSHA has cited and assessed penalties against the Bidder for "serious," "willful" or "repeat" violations of its safety or health regulations in the past five (5) years?

- Yes (Not Qualified)
 No

3. Accuracy and Authority. The undersigned is duly authorized to execute this Qualifications Statement under penalty of perjury on behalf of the above-identified Bidder. The undersigned warrants and represents that he/she has personal knowledge of each of the responses to this Qualifications Statement and/or that he/she has conducted all necessary and appropriate inquiries to determine the truth, completeness and accuracy of responses to this Qualifications Statement. The undersigned declares and certifies that the responses to this Qualifications Statement are complete and accurate; there are no omissions of material fact or information that render any response to be false or misleading and there are no misstatements of fact in any of the responses. The above-identified Bidder acknowledges and agrees that if the District determines that any response herein is false or misleading or contains misstatements of fact so as to be false or misleading, the Bidder's Bid Proposal may be rejected for non-responsiveness.

Executed this ___ day of _____ 20__ at _____ (City and State)

I declare under penalty of perjury under California law that the foregoing is true and correct.

By: _____ (Signature of Bidder's Authorized Officer or Representative)

(Typed or Printed Name)

Title: _____

NON-COLLUSION AFFIDAVIT

STATE OF CALIFORNIA
COUNTY OF _____

I, _____, being first duly sworn, deposes and says
(Typed or Printed Name)

that I am the _____ of _____,
(Title) (Bidder Name)

the party submitting the foregoing Bid Proposal ("the Bidder"). In connection with the foregoing Bid Proposal, the undersigned declares, states and certifies that:

1. The Bid Proposal is not made in the interest of, or on behalf of, any undisclosed person, partnership, company, association, organization or corporation.
2. The Bid Proposal is genuine and not collusive or sham.
3. The bidder has not directly or indirectly induced or solicited any other bidder to put in a false or sham bid, and has not directly or indirectly colluded, conspired, connived, or agreed with any other bidder or anyone else to put in a sham bid, or to refrain from bidding.
4. The bidder has not in any manner, directly or indirectly, sought by agreement, communication, or conference with anyone to fix the bid price, or that of any other bidder, or to fix any overhead, profit or cost element of the bid price or that of any other bidder, or to secure any advantage against the public body awarding the contract or of anyone interested in the proposed contract.
5. All statements contained in the Bid Proposal and related documents are true.
6. The bidder has not, directly or indirectly, submitted the bid price or any breakdown thereof, or the contents thereof, or divulged information or data relative thereto, or paid, and will not pay, any fee to any person, corporation, partnership, company, association, organization, bid depository, or to any member or agent thereof to effectuate a collusive or sham bid.

Executed this _____ day of _____, 20____ at _____.
(City, County and State)

I declare under penalty of perjury under the laws of the State of California that the foregoing is true and correct.

Signature

Name Printed or Typed

CERTIFICATE OF WORKERS' COMPENSATION INSURANCE

I, _____ the _____ of
 (Name) (Title)

_____, declare, state and certify that:
 (Contractor Name)

1. I am aware that California Labor Code §3700(a) and (b) provides:

“Every employer except the state shall secure the payment of compensation in one or more of the following ways:

(a) By being insured against liability to pay compensation in one or more insurers duly authorized to write compensation insurance in this state.

(b) By securing from the Director of Industrial Relations a certificate of consent to self-insure either as an individual employer, or one employer in a group of employers, which may be given upon furnishing proof satisfactory to the Director of Industrial Relations of ability to self-insure and to pay any compensation that may become due to his or her employees”.

2. I am aware that the provisions of California Labor Code §3700 require every employer to be insured against liability for workers' compensation or to undertake self-insurance in accordance with the provisions of that code, and I will comply with such provisions before commencing the performance of this Contract.

3. The following information pertains to the Workers Compensation Insurance policy:

Name of Insurer	
Policy No.	
Expiration Date	
Name, Address, Telephone, Fax and Email Address of contact for Insurer or Broker	

 (Contractor Name)

By _____
 (Signature)

 (Typed or printed name)

DRUG-FREE WORKPLACE CERTIFICATION

I, _____, am the _____ of
(Print Name) (Title)

_____. I declare, state and certify to all of the following:
(Contractor Name)

1. I am aware of the provisions and requirements of California Government Code §§8350 et seq., the Drug Free Workplace Act of 1990.

2. I am authorized to certify, and do certify, on behalf of Contractor that a drug free workplace will be provided by Contractor by doing all of the following:

A. Publishing a statement notifying employees that the unlawful manufacture, distribution, dispensation, possession or use of a controlled substance is prohibited in Contractor’s workplace and specifying actions which will be taken against employees for violation of the prohibition;

B. Establishing a drug-free awareness program to inform employees about all of the following:

- (i) The dangers of drug abuse in the workplace;
- (ii) Contractor’s policy of maintaining a drug-free workplace;
- (iii) The availability of drug counseling, rehabilitation and employee-assistance programs; and
- (iv) The penalties that may be imposed upon employees for drug abuse violations;

C. Requiring that each employee engaged in the performance of the Contract be given a copy of the statement required by subdivision (A), above, and that as a condition of employment by Contractor in connection with the Work of the Contract, the employee agrees to abide by the terms of the statement.

3. Contractor agrees to fulfill and discharge all of Contractor’s obligations under the terms and requirements of California Government Code §8355 by, *inter alia*, publishing a statement notifying employees concerning: (a) the prohibition of any controlled substance in the workplace, (b) establishing a drug-free awareness program, and (c) requiring that each employee engaged in the performance of the Work of the Contract be given a copy of the statement required by California Government Code §8355(a) and requiring that the employee agree to abide by the terms of that statement.

4. Contractor and I understand that if the District determines that Contractor has either: (a) made a false certification herein, or (b) violated this certification by failing to carry out and to implement the requirements of California Government Code §§8355, the Contract awarded herein is subject to termination, suspension of payments, or both. Contractor and I further understand that, should Contractor violate the terms of the Drug-Free Workplace Act of 1990, Contractor may be subject to debarment in accordance with the provisions of California Government Code §§8350, et seq.

5. Contractor and I acknowledge that Contractor and I are aware of the provisions of California Government Code §§8350, et seq. and hereby certify that Contractor and I will adhere to, fulfill, satisfy and discharge all provisions of and obligations under the Drug-Free Workplace Act of 1990.

I declare under penalty of perjury under the laws of the State of California that all of the foregoing is true and correct.

Executed at _____ this ____ day of _____, 20____.
(City and State)

(Signature)

(Handwritten or Typed Name)

CONTRACT FOR LABOR AND MATERIALS

This Contract for Labor and Materials (“Contract”) is entered into this [Click here to enter a date.](#) by and between **IMPERIAL COMMUNITY COLLEGE DISTRICT** (“District”) and _____ (“Contractor”) for the Work of the Project generally described as **BUILDING 700 – TRANSFORMER UPGRADE**. In consideration of the mutual covenants set forth herein, the Contractor and District agree as follows:

1. **Contract Price.** In consideration of the payment of the sum of _____ Dollars (\$ _____) (“the Contract Price”), the Contractor shall perform and complete the Work generally described as **BUILDING 700 – TRANSFORMER UPGRADE**.
2. **Contract Time and Liquidated Damages.** Contractor shall commence the Work on the date indicated in the Notice to Proceed issued by or on behalf of the District and shall complete the Work within One Hundred Fifty (150) calendar days after the commencement date for the Work (“the Contract Time”). Failure to complete the Work within the Contract Time will subject the Contractor to Liquidated Damages at the rate of Seven Hundred Fifty Dollars (\$750) per calendar day until the Work is completed.
3. **Project Site.** The location of the Work is at Building 700 (“the Site”).
4. **Contractor and Subcontractor Insurance.** At all times during the Work, the Contractor and each Subcontractor shall obtain and maintain the following insurance coverages:

Contractor Insurance	
Policy of Insurance	Minimum Coverage Limit
Workers’ Compensation Insurance	In accordance with Laws
Employer’s Liability Insurance	One Million Dollars (\$1,000,000)
Commercial General Liability and Property Insurance	Per occurrence: One Million Dollars (\$1,000,000)
	Aggregate: Two Million Dollars (\$2,000,000)
Automobile Liability Insurance (combined single limit)	Five Hundred Thousand Dollars (\$500,000)
Contractor Pollution Liability Insurance	One Million Dollars (\$1,000,000) per claim and One Million Dollars (\$1,000,000) in the aggregate
Builder’s Risk “All-Risk” Insurance	Full insurable value of Work Seismic coverage is required

Subcontractors’ Insurance	
Policy of Insurance	Minimum Coverage Limit
Workers’ Compensation Insurance	In accordance with Laws
Employer’s Liability Insurance	One Million Dollars (\$1,000,000)
Commercial General Liability and Property Insurance	Per occurrence: Five Hundred Thousand Dollars (\$500,000)
	Aggregate: One Million Dollars (\$1,000,000)
Automobile Liability Insurance (combined single limit)	Five Hundred Thousand Dollars (\$500,000)
Contractor Pollution Liability Insurance	One Million Dollars (\$1,000,000) per claim and One Million Dollars (\$1,000,000) in the aggregate

5. Change Order Mark-Up. Mark-ups on the direct costs of Changes directed or authorized by the District pursuant to Paragraph 4 of the Contract Terms and Conditions are limited to ten percent (10%) of the direct costs.

6. Contract Documents. The Contract Documents consist of this Contract for Labor and Materials, the attached Contract Terms and Conditions, the Bid Proposal and other documents submitted by the Contractor to the District as a Bidder and the documents identified below. By executing this Contract, the Contractor acknowledges its receipt and review of the Contract Documents; based upon this review, the Contractor confirms that the Work can be completed for the Contract Price and within the Contract Time. The Contract Documents consist of:

Notice to Contractors
 Instruction for Bidders
 Bid Proposal
 Subcontractors List
 Qualifications Statement
 Non-Collusion Affidavit
 Certificate of Worker's Compensation Insurance
 Drug-Free Workplace Certification

Contract For Labor and Materials
 Bid Bond
 Performance Bond
 Labor and Materials Payment Bond
 Verification of Certified Payroll Records Submittal to Labor Commissioner
 Drawings
 Specifications

7. District Representative and Architect. The District Representative is Javier Luna, Director of Facilities and Construction. The Architect, is Michael Wall Engineering.

CONTRACTORS ARE REQUIRED BY LAW TO BE LICENSED AND REGULATED BY THE CONTRACTORS' STATE LICENSE BOARD. ANY QUESTIONS CONCERNING A CONTRACTOR MAY BE REFERRED TO THE REGISTRAR, CONTRACTORS' STATE LICENSE BOARD, P.O. BOX 2600, SACRAMENTO, CALIFORNIA 95826

IN WITNESS WHEREOF, the District and Contractor have executed this Contract as of the date set forth above.

"District"
IMPERIAL COMMUNITY COLLEGE DISTRICT

By: _____
 Title: _____

"Contractor"
[Contractor Name]

By: _____
 Title: _____
 Fed Tax Id: _____

 (Street Address)

 (City, State, Zip Code)

 Contractor's Representative

 Contractor's Representative Email
 (_____) _____
 Contractor's Representative Telephone

TERMS AND CONDITIONS OF CONTRACT FOR LABOR AND MATERIALS

1. Labor and Materials. The Contractor shall furnish and pay for all labor, materials, equipment and services necessary to complete the Work in accordance with the Contract Documents. Unless otherwise expressly provided for in the Contract Documents, all materials, equipment and other items incorporated into the Work shall be new and of the most suitable grade and quality for the purpose intended. The Work is subject to tests/inspections as required by the Contract Documents. The Contractor shall afford the District, the Project Inspector, the Architect and test/inspection services with access to the Work, wherever located and whether in place or in progress. All of the Work shall conform with the requirements of the Contract Documents and applicable laws, ordinances, rules and regulations.

2. Submittals. The Contractor shall submit to the District Representative or the Architect, as designated in the Contract Documents, shop drawings, product data and other submittals (collectively "Submittals") required by the Contract Documents promptly and in an orderly sequence while allowing sufficient time for review and comment. No portion of the Work requiring Submittals shall be performed until the required Submittals have been reviewed and accepted.

3. Construction Schedule. If required by the District or by the Contract Documents, the Contractor shall prepare a Construction Schedule in such form and format as directed by the District. The Construction Schedule shall reflect all activities necessary to complete the Work and shall be in such detail as required by the District. If a schedule is required, the Contractor shall update the schedule monthly or more frequently as directed by the District or required by the circumstances of the Work. If a Construction Schedule is included as part of the Contract Documents, the Contractor shall complete the Work in accordance with such Construction Schedule.

4. Changes.

4.1 Changes to the Work. The District may, by written order, make Changes to the Work, issue additional instructions and to add to or delete from the Work. No Change may be made without the prior written approval and direction of the District. Adjustments of the Contract Price or the Contract Time on account of a Change authorized hereunder will only be made by written Change Order duly executed by the Contractor and the District Representative. Adjustments to the Contract Price for authorized Changes shall be limited to the direct costs of labor and materials necessary to complete the Change plus a mark-up on the direct costs set forth in the Contract. The mark-up represents all compensation due the Contractor for profit, overhead/administrative costs and impacts of a Change. Changes approved by the District shall be reduced to a written Change Order in the form and substance established by the District.

4.2 Substitutions. No substitution of any specified item, product, material or system ("Specified Items") will be considered unless the Contractor submits a request to substitute Specified Items along with data substantiating the equivalency of the proposed substitution with the Specified Items not more than thirty-five (35) days after the date of award of the Contract to the Contractor. The Contractor shall reimburse the District for all costs and expenses incurred by the District to review a proposed substitution for Specified Items. The District's acceptance or rejection of a proposed substitution shall be final. No substitution accepted by the District shall increase the Contract Price or the Contract Time; provided, however, if the cost to furnish/install an approved substitution of is less than the specified Item, the Contract Price shall be reduced by such cost difference. If any Specified Items are identified in any portion of the Contract Documents as "District Standard Materials/Equipment" "match existing in use" or similar words/phrases, in accordance with Public Contract Code §3400, the District shall be deemed to have made a finding that such Specified Items are designated as "sole source" items designed to match existing and in use items.

In accordance with Public Contract Code §3400, the District will not consider or accept alternatives or substitutions for any Specified Items so identified.

5. Payment Bond; Performance Bond. Prior to commencement of Work, the Contractor shall obtain and deliver to the District a Labor and Materials Payment Bond and a Performance Bond. Bonds required hereunder will be accepted by the District only if: (i) they are in the form and content included in the Contract Documents; (ii) the Bonds are issued by an Admitted Surety Insurer under California law; and (iii) in a penal sum equal to one hundred percent (100%) of the Contract Price.

6. Safety; Security. The Contractor shall comply with all applicable laws, ordinances, rules, or regulations pertaining to safety at the Site. The Contractor shall implement safety measures such as fencing, barricades, signs, lights and other precautions to prevent injury or death to persons or damage to property. The Contractor is responsible for securing the Site and Work in place or in progress (including materials/equipment/tools situated at the Site) to prevent theft, loss or damage.

7. Labor.

7.1 Prevailing Wage Rates; Hours of Work. The Contractor and all Subcontractors shall: (i) pay their respective workers wage rates not less than the prevailing wage rate established for the classification, trade or work performed by each worker; (ii) maintain complete and accurate payroll records for workers engaged in the Work; and (iii) complete and submit Certified Payroll Records to the Labor Commissioner. The Contractor and Subcontractors shall not permit any worker to provide more than eight (8) hours of work per day or forty (40) hours per week without additional compensation as mandated by law. The Contractor shall be subject to all penalties and assessments provided by law or regulation for violation(s) of the prevailing wage rate requirements or hours of work limitations.

7.2 Apprentices. Apprentices, if any engaged in performing any portion of the Work shall be in strict conformity with applicable laws, rules and regulations, including without limitation, Labor Code §§1777.5 through 1777.7, which are incorporated herein by this reference.

7.3 Competency and Discipline. The Contractor shall enforce strict discipline and good order among the Contractor's employees, the employees of any Subcontractor and all other persons performing any part of the Work at the Site. Personnel of the Contractor or any Subcontractor shall be subject to removal from the Site for violations of applicable law or District policies. The Contractor shall not permit employment of unfit persons or persons not skilled in tasks assigned to them and shall dismiss from its employ and direct any Subcontractor to dismiss from their employment any person deemed by the District to be unfit or incompetent to perform Work.

7.4 Superintendent. The Contractor shall employ a Superintendent fluent in verbal and written English who shall be at the Site at all times during performance of Work at the Site. The Superintendent is the Contractor's Representative for the Work; directions, instructions or other communications to or with the Contractor's Superintendent shall be deemed directions, instructions or communications to or with the Contractor.

7.5 Compliance With District Policies. All personnel of the Contractor and Subcontractors shall comply with District policies, including policies prohibiting use of or possession of: tobacco and tobacco products of any form, alcohol, illegal/controlled substances and weapons while on District property.

8. Subcontractors. The Work of each Subcontractor shall be set forth in a written Subcontract agreement incorporating by reference this Contract; Subcontracts shall be made available to the District for review upon request of the District. The Contractor is responsible to the District for the acts, omissions and other conduct of Subcontractors. Each Subcontractor shall maintain Workers

Compensation/Employers Liability Insurance and Commercial General Liability Insurance as required by the Contract for Labor and Materials.

9. Non-Discrimination. The Contractor and its Subcontractors shall not discriminate against any active or prospective employee based upon race, color, ancestry, national origin, religion, sex, age, sexual preference or marital status. The Contractor and its Subcontractors shall comply with all applicable laws, ordinances, rules and regulations prohibiting workplace discrimination and/or discriminatory employment practices.

10. Contract Price.

10.1 Contractor Payment Application. The District will make payment of the Contract Price upon completion of the Work, the Contractor's full performance of all other obligations under this Contract and the Contractor's submission of an Application for Payment ("Payment Application") in such form and content as required by the District. Each Payment Application shall be accompanied by the form of Verification of Certified Payroll Records Submittal to Labor Commissioner included with the Contract Documents.

10.2 Contract Price Payment.

10.2.1 Contract Time 60 Days or Less. If the Contract Time is sixty (60) days or less, upon completion of the Work and all other obligations of the Contractor, the Contractor may submit a Payment Application for the entire Contract Price. Upon receipt of the Payment Application, the District Representative will verify that the Work has been completed and that the Contractor has performed all other obligations under the Contract Documents. Within thirty (30) days of the District Representative confirmation of the completion of Work and the Contractor's performance of other obligations hereunder, the District will make payment of the Contract Price.

10.2.2 Contract Time More than Sixty (60) Days. If the Contract Time is a duration of sixty (60) days or more, the Contractor may submit Payment Applications on a monthly basis for the value of Work completed in the prior month. Upon receipt of a Payment Application, the District Representative will promptly verify that the Work has been completed as indicated in the Payment Application. Within thirty (30) days of the date of such verification, the District will make payment equal to ninety-five percent (95%) of the value of the Work completed as verified by the District Representative. Upon the Contractor's completion of the Work and all other Contractor obligations under the Contract Documents, the Contractor may submit a Payment Application for payment of sums retained from prior Payment Applications. The District's obligation to disburse the Contract Price, or any portion thereof is expressly subject to the following conditions precedent: (i) the Contractor's preparation of a Schedule of Values for review and acceptance by the District's Representative; (ii) the submittal of executed Waivers and Releases (on Progress Payment or Final Payment, as applicable) for the Contractor and all Subcontractors receiving any portion of the Contract Price; and (iii) submittal of the Verification of Certified Payroll Submittal to Labor Commissioner.

10.2.3 Withholding of Contract Price. The District may withhold payment of any portion of the Contract Price for: (i) claims or the probability of claims being submitted by Subcontractor, Material Suppliers or others in connection with the Work; (ii) defective or non-conforming Work which is not remedied; (iii) uncured Contractor defaults; or (iv) any amount due from the Contractor to the District under the Contract Documents, including without limitation Liquidated Damages.

11. Insurance. The Contractor and its Subcontractors shall, at all times during the Work, maintain Workers Compensation, Employers Liability, and Commercial General Liability Insurance in the minimum coverage amounts set forth in the Contract. The Contractor's Commercial General Liability

Insurance shall name the District as an Additional Insured. The Contractor shall maintain a policy of Builders Risk Insurance covering the full insurable value of the Work; if noted as a requirement in the Contract, the Builder's Risk Insurance shall include seismic coverage. All policies of insurance shall include provisions that the policy of insurance will not be materially modified, cancelled or allowed to expire without at least thirty (30) days advance notice to the District. Prior to commencing the Work, the Contractor shall deliver Certificates of Insurance of itself and its Subcontractors evidencing the required insurance coverages. No Work at the Site by the Contractor or any Subcontractor will be permitted unless the Contractor and Subcontractor, as applicable has/have submitted Certificates of Insurance evidencing the required insurance policies hereunder to the District Representative. Policies of insurance required of the Contractor and Subcontractors is primary; policies of insurance maintained by the District are excess and non-contributory to the Contractor/Subcontractor policies of insurance. All policies of insurance shall be issued by insurers AM Best rated at least VII/A-.

12. Indemnification.

12.1 Contractor Indemnification. To the fullest extent permitted by law, the Contractor shall indemnify, defend and hold harmless the District, the District's Board of Trustees and all members thereof and the District's employees, officers, agents and representatives (collectively "Indemnified Parties") from all claims, demands, causes of action, losses, damages or liabilities, including without limitation, attorneys' fees and other related legal fees, costs and expenses, which arise out of or related in any manner to the negligent, grossly negligent or willful conduct of the Contractor, its Subcontractors or their respective employees, agents or representatives in connection with the Work or performance of obligations hereunder. The Contractor's obligations hereunder include without limitation: (i) injury to, or death of, persons; (ii) damage to property; (iii) theft or loss of property; (iv) Stop Payment Notice claims; and (v) other losses, damages or costs arising out of, in whole or in part, of the negligent, grossly negligent or willful conduct of the Contractor or Subcontractors. The Contractor's obligations hereunder shall survive termination of the Contract and/or completion of the Work, and incorporated into and made a part of the obligations of the Surety issuing the Performance Bond.

12.2 District Indemnification. The District will indemnify and hold harmless the Contractor from claims arising out of bodily injury or death of persons or damage to property which arise out of the negligent, grossly negligent or willful conduct of the District.

13. Termination; Suspension.

13.1 Termination for Contractor Default. The Contractor's failure to comply with any term or condition of the Contract Documents shall constitute default of the Contractor. In such event, the District may terminate the Contract upon seven (7) days written notice to the Contractor. The District may, in the District's sole and exclusive discretion, afford the Contractor an opportunity to cure the Contractor's default. In such event, the Contractor commences, and diligently thereafter prosecutes to completion, all required actions to cure such default(s), this Contract shall be deemed terminated, effective as of the seventh (7th) day after the date of the District's written notice. If the District terminates the Contract for default of the Contractor, the Contractor and the Performance Bond Surety shall be jointly and severally liable to the District for all losses, costs and damages arising out of the Contractor's default and costs to complete the Work which exceeds the remaining Contract Price at the time of termination.

13.2 Termination for District Convenience. The District may terminate this Contract, in whole or in part, at any time for the convenience of the District and without fault or neglect of the Contractor by written notice to the Contractor, setting forth the effective date of such termination. If the Contract is terminated for the District's convenience, the Contract Price shall

be limited to the value of the Work in place or in progress as of the effective date of termination for the District's convenience.

13.3 Suspension.

13.3.1 District's Right to Suspend Work. The District may, without cause, and without invalidating or terminating the Contract, order the Contractor, in writing, to suspend, delay or interrupt the Work in whole or in part for such period of time as the District may determine. When all or a portion of the Work is to be suspended for any reason, the Contractor and each Subcontractor shall cover over, and securely fasten down all coverings, to protect the Work from damage, destruction or deterioration from any cause. The Contractor shall resume and complete the Work suspended by the District in accordance with the District's directive, whether issued at the time of the directive suspending the Work or subsequent thereto.

13.3.2 Adjustments to Contract Price and Contract Time. If the District orders suspension of the Work, an adjustment shall be made to the Contract Price for increases in the direct cost of performance of the Work of the Contract Documents, actually caused by suspension, delay or interruption ordered by the District; provided however that no adjustment of the Contract Price shall be made to the extent: (i) that performance is, was or would have been so suspended, delayed or interrupted by another cause for which the Contractor is responsible under the Contract Documents; or (ii) that an equitable adjustment is made or denied under another provision of the Contract Documents. The foregoing notwithstanding, any such adjustment of the Contract Price shall not include any adjustment to increase the Contractor's overhead, general administrative costs or profit, all of which will remain as reflected in the Cost Breakdown submitted by the Contractor pursuant to the Contract Documents. In the event of the District's suspension of the Work, the Contract Time shall be equitably adjusted.

14. Warranty. In addition, to warranties arising by operation of law, the Contractor warrants that the Work, materials/equipment incorporated therein and workmanship conform to requirements of the Contract Documents and are not defective. If within one (1) year or such other period set forth in the Contract Documents, any of the Work, materials/equipment or workmanship are determined to be defective or not in compliance with the Contract Documents, the Contractor shall upon the District's demand, promptly take all measures necessary to correct, repair or replace such Work materials/equipment or workmanship. If the Contractor fails to do so, the District may take necessary action to correct, replace or replace such Work, materials/equipment or workmanship at the cost and expense of the Contractor. The Performance Bond obligations include the foregoing warranty obligations of the Contractor.

15. Tests/Inspections of the Work. The Work shall be subject to tests/inspections if required by the Contract Documents. The Contractor shall be liable for costs of tests/inspections which result from the Work: (i) not being ready for tests/inspections; or (ii) the failure of the Work to comply with the applicable test/inspection standards. If the Work is subject to the jurisdiction of the Division of State Architect ("DSA"), all of the Work shall be subject to inspection/observation by the Project Inspector retained by the District under DSA regulations.

16. Miscellaneous.

16.1 Claims Resolution.

16.1.1 Contractor Continuation of Work. Notwithstanding any claim, dispute, disagreement or other matter in controversy between the District and the Contractor relating to the Contract Documents or the Project Work, the Contractor shall continue to diligently

prosecute and perform the Work, pending any final determination or decision regarding any such claim, dispute, disagreement or matter in controversy.

16.1.2 Public Contract Code §9204 Claims Resolution Procedures. Claims of the Contractor are subject to the non-binding dispute resolution procedures set forth in Public Contract Code §9204 (“Section 9204”).

16.1.2.1 Contractor Claims. Contractor Claims are subject to the Section 9204 Procedures provided, however, that the Section 9204 Procedures are expressly subject to the Contractor’s prior full and timely compliance with requirements and procedures of the Contract Documents relating to submittal and resolution of Claims, change orders, disputes and other matters in controversy under the Contract Documents. By this reference, the Section 9204 Procedures are incorporated herein.

16.1.2.2 Subcontractor Claims. Subcontractor Claims are subject to Section 9204 Procedures, as modified herein. The District’s review of Subcontractor Claims is expressly subject to the Contractor’s submittal of a duly completed and executed form of Contractor Certification of Subcontractor Claim certifying that the Contractor has thoroughly reviewed the Subcontractor Claim and based on the Contractor’s review, certify that: (i) the Subcontractor Claim is made by the Subcontractor in good faith; (ii) the Subcontractor Claim is supported by reasonable documentation establishing entitlement to the relief requested and District liability therefor; and (iii) the Subcontractor Claim does not incorporate any request constituting a False Claim under applicable law, including the California False Claim Act (Government Code §12650 et seq.). The form of Contractor Certification of Subcontractor Claim is included in the Contract Documents.

16.1.2.3 Contractor Compliance with Government Code Claims Procedures. Disputed Claims and other matters in controversy asserted by the Contractor against the District are a “suit for money or damages” and subject to Government Code §§945.4, 945.6 and 946 (“Government Code Claims Process”). An express condition precedent to the Contractor’s initiation of §20104.4 Dispute Resolution Procedures is the Contractor’s compliance with the Government Code Claims Process.

16.1.3 Disputed Claims. Disputed Claims of \$375,000 or less shall be resolved in accordance with the civil action procedures established in Public Contract Code §20104.4. Mediation conducted pursuant to Section 9204 Procedures shall excuse any further obligation under Section 20104.4 to mediate after litigation has been commenced.

16.2 Governing Law; Interpretation. This Contract shall be governed by the laws of the State of California. This Contract shall be interpreted as a whole and not in favor of the District or the Contractor.

16.3 Successors. This Contract shall be binding upon and inure to the benefit of the respective successors-in-interest of the District and the Contractor. The foregoing notwithstanding, the Contractor shall not assign this Contract, any right or obligation hereunder or any portion thereof.

16.4 Permits; Approvals. Unless otherwise expressly provided in the Contract Documents, the District shall obtain and pay for all fees, permits or approvals necessary for construction of the Work.

16.5 Force Majeure. Neither Contractor or District will be responsible to the other for damages, loss, injury, or delay caused by conditions that are beyond the reasonable control and without the willful, grossly negligent or negligent conduct of that party, including, without limitation acts of God; acts of government agencies; condemnation; strikes; labor disputes; fires; explosions or other casualties; thefts; vandalism; riots or war; acts of terrorism; electrical power outages; interruptions or degradations in telecommunications, computer, or electronic communications systems; changes in Laws;; plague, epidemic, pandemic, outbreaks of infectious disease or any other public health crisis, including quarantine or other employee restrictions.

16.6 Waiver of Consequential and Special Damages. Notwithstanding any right conferred by law or arising by operation of law, by executing the Agreement, the Contractor expressly waives and relinquishes any and all right or entitlement to assert or recover any damages, losses or liabilities from the District which are in the nature of special or consequential damages, losses or liabilities arising out of or related in any manner to the District's breach or default of its obligations under the Contract Documents.

16.7 Days. Unless otherwise stated in the Contract Documents, all references to "days" shall be deemed references to calendar days.

16.8 Severability. If any term, condition or provision of this Contract is deemed invalid, illegal or unenforceable by a Court of competent jurisdiction, such term, condition or provision shall be deemed severed herefrom, but all other terms, conditions and provisions hereof shall remain unaffected and in full force and effect.

16.9 Entire Agreement. This Contract and the Contract Documents constitute the entire agreement and understanding of the District and the Contractor concerning the subject matter hereof.

[END OF SECTION]

BID BOND

KNOW ALL MEN BY THESE PRESENTS that we, _____, as Surety and _____, as Principal, are jointly and severally, along with their respective heirs, executors, administrators, successors and assigns, held and firmly bound unto **IMPERIAL COMMUNITY COLLEGE DISTRICT** (“the Obligee”) for payment of the penal sum hereof in lawful money of the United States, as more particularly set forth herein.

THE CONDITION OF THIS OBLIGATION IS SUCH THAT:

WHEREAS, the Principal has submitted the accompanying Bid Proposal to the Obligee for the Work commonly described as **BUILDING 700 – TRANSFORMER UPGRADE**.

WHEREAS, subject to the terms of this Bond, the Surety and the Principal are jointly and severally firmly bound unto the Obligee in the penal sum equal to Ten Percent (10%) of the maximum amount of the Bid Proposal submitted by the Principal to the Obligee, inclusive of amounts proposed for additive Alternate Bid Items, if any.

NOW THEREFORE, if the Principal shall not withdraw said Bid Proposal within the period specified therein after the opening of the same, or, if no period be specified, for sixty (60) days after opening of said Bid Proposal; and if the Principal is awarded the Contract, and shall within the period specified therefore, or if no period be specified, within five (5) days after the prescribed forms are presented to him for signature, enter into a written contract with the Obligee, in accordance with the Bid Proposal as accepted and give such bond(s) with good and sufficient surety or sureties, as may be required, for the faithful performance and proper fulfillment of such Contract and for the payment for labor and materials used for the performance of the Contract, or in the event of the withdrawal of said Bid Proposal within the period specified for the holding open of the Bid Proposal or the failure of the Principal to enter into such Contract and give such bonds within the time specified, if the Principal shall pay the Obligee the difference between the amount specified in said Bid Proposal and the amount for which the Obligee may procure the required Work and/or supplies, if the latter amount be in excess of the former, together with all costs incurred by the Obligee in again calling for bids, then the above obligation shall be void and of no effect, otherwise to remain in full force and effect.

Surety, for value received, hereby stipulates and agrees that no change, extension of time, alteration or addition to the terms of the Contract or the Call for Bids, the Work to be performed thereunder, the Drawings or the Specifications accompanying the same, or any other portion of the Contract Documents shall in no way affect its obligations under this Bond, and it does hereby waive notice of any such change, extension of time, alteration or addition to the terms of said Contract, the Call for Bids, the Work, the Drawings or the Specifications, or any other portion of the Contract Documents.

[CONTINUED NEXT PAGE]

In the event suit or other proceeding is brought upon this Bond by the Obligee, the Surety and Principal shall be jointly and severally liable for payment to the Obligee all costs, expenses and fees incurred by the Obligee in connection therewith, including without limitation, attorneys' fees.

IN WITNESS WHEREOF, the Principal and Surety have executed this instrument this _____ day of _____, 20____ by their duly authorized agents or representatives.

(Bidder/Principal Name)

By: _____
(Signature)

(Typed or Printed Name)

Title: _____

(Attach Notary Public Acknowledgement of Principal's Signature)

(Surety Name)

By: _____
(Signature of Attorney-In-Fact for Surety)

(Typed or Printed Name of Attorney-In-Fact)

(Attach: (i) Attorney-In-Fact Certification; (ii) Notary Public Acknowledgment of Authorizing Signature on Attorney-Fact Certification; and (iii) Notary Public Acknowledgement of Attorney-In-Fact's Signature.)

Contact name, address, telephone number and email address for notices to the Surety

(Contact Name)

(Street Address)

(City, State & Zip Code)

(_____) _____ (_____) _____
Telephone Fax

(Email address)

PERFORMANCE BOND

KNOW ALL MEN BY THESE PRESENTS that we, _____, as Surety and _____, as Principal, are jointly and severally, along with their respective heirs, executors, administrators, successors and assigns, held and firmly bound unto **IMPERIAL COMMUNITY COLLEGE DISTRICT** (“the Obligee”) for payment of the penal sum of _____ Dollars (\$_____) in lawful money of the United States, well and truly to be made, we bind ourselves, our heirs, executors, administrators, successors and assigns, jointly and severally.

THE CONDITION OF THIS OBLIGATION IS SUCH THAT:

WHEREAS, the Obligee, by resolution of its Board of Trustees has awarded to the Principal a Contract for the Work described as **BUILDING 700 – TRANSFORMER UPGRADE**.

WHEREAS, the Principal, has entered into an agreement with the Obligee for performance of the Work; the Agreement and all other Contract Documents set forth therein are incorporated herein and made a part hereof by this reference.

WHEREAS, by the terms of the Contract Documents, the Principal is required to furnish a bond ensuring the Principal’s prompt, full and faithful performance of the Work of the Contract Documents.

NOW THEREFORE, if the Principal promptly, fully and faithfully performs each and all of the obligations and things to be done and performed by the Principal in strict accordance with the terms of the Contract Documents as they may be modified or amended from time to time; and if the Principal indemnifies and saves harmless the Obligee and all of its officers, agents and employees from any and all losses, liability and damages, claims, judgments, liens, costs, and fees of every description, which may be incurred by the Obligee by reason of the failure or default on the part of the Principal in the performance of any or all of the terms or the obligations of the Contract Documents, including all modifications, and amendments, thereto, and any warranties or guarantees required thereunder; then this obligation shall be void; otherwise, it shall be, and remain, in full force and effect.

The Surety, for value received, hereby stipulates and agrees that no change, adjustment of the Contract Time, adjustment of the Contract Price, alterations, deletions, additions, or any other modifications to the terms of the Contract Documents, the Work to be performed thereunder, or to the Specifications or the Drawings shall limit, restrict or otherwise impair Surety’s obligations or Obligee’s rights hereunder. The Surety hereby waives notice from the Obligee of any such changes, adjustments of Contract Time, adjustments of Contract Price, alterations, deletions, additions or other modifications to the Contract Documents, the Work to be performed under the Contract Documents, or the Drawings or the Specifications.

If the Obligee terminates the Contract due to the Principal’s breach or default of the Principal’s obligations thereunder, within twenty (20) days after written notice from the Obligee to the Surety of the Principal’s breach or default of the Contract Documents and Obligee’s termination of the Contract, the Surety shall notify Obligee in writing of Surety’s assumption of obligations hereunder by its election to either remedy the default or breach of the Principal or to take charge of the Work of the Contract Documents and complete the Work at its own expense (“the Notice of Election”); provided, however, that the procedure by which the Surety undertakes to discharge its obligations under this Bond shall be subject to the advance written approval of the Obligee, which approval shall not be unreasonably withheld, limited or restricted. The insolvency of the Principal or the Principal’s denial of a failure of performance or default under the Contract Documents shall not by itself, without the Surety’s prompt, diligent inquiry and investigation of such denial, be justification for Surety’s failure to give the Notice of Election or for its failure to promptly remedy the failure of performance or default of the Principal or to complete the Work.

If the Surety fails to issue its Notice of Election to Obligee within the time provided for hereinabove, the Obligee may thereafter cause the cure or remedy of the Principal's failure of performance or default or to complete the Work. The Principal and the Surety shall be jointly and severally liable to the Obligee for all damages and costs sustained by the Obligee as a result of the Principal's failure of performance under the Contract Documents or default in its performance of obligations thereunder, including without limitation the costs of cure or completion of the Work exceeding the then remaining balance of the Contract Price; provided that the Surety's liability hereunder for the costs of performance, damages and other costs sustained by the Obligee upon the Principal's failure of performance or default under the Contract Documents shall be limited to the penal sum hereof, which shall be deemed to include the costs or value of any Changes to the Work which increases the Contract Price. If suit or other proceeding is brought upon this Bond by the Obligee, the Surety and Principal shall be jointly and severally liable for payment to the Obligee of all costs, expenses and fees incurred by the Obligee therewith, including without limitation, attorneys' fees.

IN WITNESS WHEREOF, the Principal and Surety have executed this instrument this ____ day of _____, 20____ by their duly authorized agent or representative

(Bidder/Principal Name)

By: _____
 (Signature)

 (Typed or Printed Name)

Title: _____

(Attach Notary Public Acknowledgement of Principal's Signature)

(Surety Name)

By: _____
 (Signature of Attorney-In-Fact for Surety)

 (Typed or Printed Name of Attorney-In-Fact)

(Attach: (i) Attorney-In-Fact Certification; (ii) Notary Public Acknowledgment of Authorizing Signature on Attorney-Fact Certification; and (iii) Notary Public Acknowledgement of Attorney-In-Fact's Signature.)

Contact name, address, telephone number and email address for notices to the Surety

 (Contact Name)

 (Street Address)

 (City, State & Zip Code)

(_____) _____ (_____) _____
 Telephone Fax

 (Email address)

LABOR AND MATERIALS PAYMENT BOND

KNOW ALL MEN BY THESE PRESENTS that we, _____, as Surety and _____, as Principal, are jointly and severally, along with their respective heirs, executors, administrators, successors and assigns, held and firmly bound unto **IMPERIAL COMMUNITY COLLEGE DISTRICT** (“the Obligee”) for payment of the penal sum of _____ Dollars (\$_____) in lawful money of the United States, well and truly to be made, we bind ourselves, our heirs, executors, administrators, successors and assigns, jointly and severally.

THE CONDITION OF THIS OBLIGATION IS SUCH THAT:

WHEREAS, the Obligee, by resolution of its Board of Trustees has awarded to the Principal a Contract for the Work described as **BUILDING 700 – TRANSFORMER UPGRADE.**

WHEREAS, the Principal, has entered into an Agreement with the Obligee for performance of the Work, the Agreement and all other Contract Documents set forth therein are incorporated herein by this reference and made a part hereof.

WHEREAS, by the terms of the Contract Documents, the Principal is required to furnish a bond for the prompt, full and faithful payment to any Claimant, as hereinafter defined, for all labor materials or services used, or reasonably required for use, in the performance of the Work.

NOW THEREFORE, if the Principal shall promptly, fully and faithfully make payment: (i) to any Claimant for all labor, materials or services used or reasonably required for use in the performance of the Work; (ii) of amounts due under the Unemployment Insurance Code for work or labor performed under the Contract; and (iii) of amounts required to be deducted, withheld and paid to the Employment Development Department from wages of the employees of the Principal and its Subcontractors under Section 13020 of the Unemployment Insurance Code with respect to work and labor under the Contract then this obligation shall be void; otherwise, it shall be, and remain, in full force and effect.

The term “Claimant” shall refer to any person, corporation, partnership, proprietorship or other entity including without limitation, all persons and entities described in California Civil Code §9100, providing or furnishing labor, materials or services used or reasonably required for use in the performance of the Work under the Contract Documents, without regard for whether such labor, materials or services were sold, leased or rented. This Bond shall inure to the benefit of all Claimants so as to give them, or their assigns and successors, a right of action upon this Bond.

In the event that suit is brought on this Bond by any Claimant for amounts due such Claimant for labor, materials or services provided or furnished by such Claimant, the Surety shall pay for the same and reasonable attorneys’ fees pursuant to California Civil Code §9554.

The Surety, for value received, hereby stipulates and agrees that no change, extension of time, alteration, deletion, addition, or any other modification to the terms of the Contract Documents, the Work to be performed thereunder, the Specifications or the Drawings, or any other portion of the Contract Documents, shall in any way limit, restrict or otherwise affect its obligations under this Bond; the Surety hereby waives notice from the Obligee of any such change, extension of time, alteration, deletion, addition or other modification to the Contract Documents, the Work to be performed under the Contract

[CONTINUED NEXT PAGE]

Documents, the Drawings or the Specifications of any other portion of the Contract Documents.

IN WITNESS WHEREOF, the Principal and Surety have executed this instrument this _____ day of _____, 20__ by their duly authorized agent or representative.

(Bidder/Principal Name)

By: _____
(Signature)

(Typed or Printed Name)

Title: _____

(Attach Notary Public Acknowledgement of Principal's Signature)

(Surety Name)

By: _____
(Signature of Attorney-In-Fact for Surety)

(Typed or Printed Name of Attorney-In-Fact)

(Attach: (i) Attorney-In-Fact Certification; (ii) Notary Public Acknowledgment of Authorizing Signature on Attorney-Fact Certification; and (iii) Notary Public Acknowledgement of Attorney-In-Fact's Signature.)

Contact name, address, telephone number and email address for notices to the Surety

(Contact Name)

(Street Address)

(City, State & Zip Code)

(_____) _____ (_____) _____
Telephone Fax

(Email address)

VERIFICATION OF CERTIFIED PAYROLL RECORDS SUBMITTAL TO LABOR COMMISSIONER

I am the _____ for _____ in
(Superintendent/Project Manager) (Contractor)
connection with _____.
(Project Name)

1. This Verification is submitted to Imperial Community College District concurrently with the Contractor's submittal of an Application for Progress Payment to the District, identified as Application for Progress Payment No. _____ ("the Pay Application").
2. The Pay Application requests the District's disbursement of a Progress Payment for the value of Work performed between _____, 20__ and _____, 20__.
3. The Contractor has submitted Certified Payroll Records ("CPR") to the Labor Commissioner for all employees of the Contractor engaged in performance of Work subject to prevailing wage rate requirements for the period of time covered by the Pay Application.
4. All Subcontractors who are entitled to any portion of payment to be disbursed pursuant to the Pay Application have submitted their CPRs to the Labor Commissioner for all of their employees performing Work subject to prevailing wage rate requirements for the period of time covered by the Pay Application.
5. I have reviewed the Contractor's CPRs submitted to the Labor Commissioner. The CPRs submitted to the Labor Commissioner by the Contractor are complete and accurate for the period of time covered by the Pay Application.
6. I have reviewed the Subcontractors' CPRs submitted to the Labor Commissioner. The CPRs submitted to the Labor Commissioner by the Subcontractors are complete and accurate for the period of time covered by the Pay Application.

I declare under penalty of perjury under California law that the foregoing is true and correct. This Verification is executed on _____, 20__ at _____.
(City and State)

By: _____

(Typed or Printed Name)

CONTRACTOR CERTIFICATION OF SUBCONTRACTOR CLAIM

To: Imperial Community College District

From _____
(Contractor Name)

Project Name: **BUILDING 700 – TRANSFORMER UPGRADE**

Pursuant to Article 16.1.2.2 of the Contract Terms and Conditions, I certify as follows:

1. The portion of the Claim made on behalf of the Subcontractor to which this certification is attached is made in good faith.
2. I have reviewed the attached Subcontractor Claim and certify that to the best of my knowledge and belief, the amounts claimed for costs, expenses and damages incurred and supporting data submitted to CM/Contractor by the Subcontractor on behalf of any and all subcontractors or suppliers to Subcontractor, of all tiers, or any person or entity under Subcontractor, are accurate and complete. Subcontractor will not submit, after the date of execution of this certification, any such supporting data, including any such new amounts that, to the best of my knowledge and belief, that are not accurate and complete.
3. The amount requested accurately reflects the amount for which the Subcontractor believes the District is liable to Contractor.
4. The Subcontractor Claim does not incorporate any request constituting a False Claim under applicable law, including the California False Claim Act (Government Code §12650 et seq).
5. I am duly authorized to certify the Subcontractor Claim on behalf of the Contractor.

I declare under penalty of perjury under the laws of the State of California that the foregoing is true and correct.

Executed at: _____, in the State of California, on _____, 20____.

(Signature)

(Print Name)

(Title)

(Name of Contractor)

Special Provisions

BUILDING 700 – TRANSFORMER UPGRADE

1. Tentative Project Schedule

The following project schedule is a tentative sequence of events based on the bidding phase and construction phase period per the contract documents. These dates may be subject to change:

Advertisement	Friday, June 25 & July 2, 2021
Mandatory On-site Job Walk (Meet at Building 2000)	Wednesday, July 7, 2021; 10:00 A.M
RFI's for Clarification Due to District	Wednesday, July 14, 2021; 2:00 P.M
Response to RFI's to Contractors Due	Thursday, July 22, 2021; 5:00 P.M
Bid Submittals Due	Wednesday, July 28, 2021; 2:00 P.M
Bid Opening	Wednesday, July 28, 2021; 3:00 P.M
Issue Notice of Intent to Award	Thursday, July 29, 2021
Board Meeting for Approval	Wednesday, August 18, 2021
Issue Notice to Proceed	Thursday, August 19, 2021
Kick-off Meeting (Meet at Building 2000)	Tuesday, August 24, 2021; A.M
Construction	August 24 – Jan. 21, 2022 (150 c. days)

2. Construction Water

Water required for construction purposes can be obtained from the Imperial Community College District at locations designated by the Director of Maintenance & Operations at no cost to the Contractor. The Contractor shall provide all required backflow preventors and pipe adaptation components as required. Contractor shall provide all necessary piping and appurtenances, including pumps and/or water trucks, to convey water to the work site. Arrangements for water from sources other than the Imperial Community College District shall be the sole responsibility of the Contractor, and no additional compensation will be allowed.

For work under this specification, outside of the City of Holtville service limit, the Contractor shall coordinate with the Imperial Irrigation District or others to obtain construction water. The Contractor shall pay the Imperial Irrigation District or other water purveyors for the construction water.

3. Clean up of Existing Streets

Dirt, dust, mud, native earth material, sand, gravel, pipe material, asphalt debris, cement debris and all other construction-related material shall be swept from the street and sidewalk areas in the vicinity of the electrical pipeline installation work on a daily basis. The material shall be removed and disposed of by the Contractor. The street and sidewalk sections to be cleaned are within the street and sidewalk areas opened to traffic. It shall not be necessary to clean the street sections cordoned off from traffic within the pipe installation trench and adjoining work area. At the conclusion of the completion of electrical pipeline installation the entire street width along the electrical pipeline shall be swept clean to the satisfaction of the District.

4. Deposition of A.C. Pavement, Native Material & Construction Debris

A.C. pavement, native material spoils, and overall construction debris resultant from trenching and other construction activities shall be removed and disposed by the Contractor. The District will not accept any deposition materials and/or debris to be dumped at the District's yard, and/or trash bins.

5. Imperial Irrigation District (IID) Contractor Notes

The IID contractor notes for this project is attached to these Special Provisions and shall be considered part of the contract documents. The Contractor shall be responsible to review and understand all underground inspection processes as listed within the IID contractor notes. The Contractor shall be responsible for all coordination with IID inspectors, to review work and provided required testing, as outline within the IID contractor notes, and Project contract documents.



IID

A century of service.
ENGINEERING

APR - 9 2021

COMPLETE

<input checked="" type="checkbox"/> CUSTOMER	<input type="checkbox"/> DISTRIBUTION SUPERVISOR	<input type="checkbox"/> _____
<input type="checkbox"/> DISTRIBUTION	<input type="checkbox"/> PROJECT MANAGER	<input type="checkbox"/> _____
<input type="checkbox"/> INSPECTOR	<input type="checkbox"/> _____	<input type="checkbox"/> _____

PROJECT SITE



**IMPERIAL
LOCATION MAP**

NOT TO SCALE



CONTRACTOR NOTES

THIS WORK REQUIRES IID UNDERGROUND INSPECTION. FOR THE UNDERGROUND INSPECTION PROCESS, SEE DETAIL PAGES 7 THRU 11 FROM THE DEVELOPER ENERGY PLANNING GUIDE. ALL EQUIPMENT OR MATERIAL INSTALLED, COVERED, OR ENCLOSED BY THE CONTRACTOR PRIOR TO IID INSPECTION SHALL BE REMOVED OR UNCOVERED FOR INSPECTION, AND REINSTALLED, AT NO EXPENSE TO IID. IID WILL NOT ACCEPT OR ENERGIZE FACILITIES THAT FAIL TO MEET THE REQUIREMENTS OUTLINED IN THE PROCESS.

DETAIL PAGES

DETAIL PAGES REFER TO THE DEVELOPER ENERGY PLANNING GUIDE (D.E.P.G.) REV. 5.0 2020, IT CAN BE OBTAINED ON THE IID WEBSITE WWW.IID.COM/ENERGY/NEW-CONSTRUCTION



CAUTION: ENERGIZED STRUCTURES & CABLE

DO NOT PERFORM ANY TYPE OF WORK ON OR AROUND ENERGIZED STRUCTURES. A QUALIFIED IID ELECTRICAL WORKER MUST BE PRESENT AT JOB SITE BEFORE ANY CONDUIT OR ANY TYPE OF WORK IS PERFORMED. PLEASE CONTACT IID INSPECTION DESK AT LA QUINTA @:(760) 398-5828 ; IMPERIAL @:(760) 482-3300. INSPECTION SCHEDULES ARE SUBJECT TO A MINIMUM 48 HOUR ADVANCE NOTICE AND ARE BY APPOINTMENT ONLY.

CUSTOMER CONTACT: JOE JACKSON
PHONE NUMBER:(760) 355-6427

PROJECT MANAGER: E.B.
DISTRIBUTION ESTIMATOR: S.A.

SERVICE NOTIFICATION: 4029692
SERVICE ORDER: 60126554

SHEET 1 OF 27



UNDERGROUND SERVICE ALERT

1-800-422-4133
CALL USA/SC

FOR UNDERGROUND LOCATING
2 WORKING DAYS BEFORE YOU DIG

IMPERIAL IRRIGATION DISTRICT
IMPERIAL, CA
IMPERIAL VALLEY ENERGY PROJECT

U.G. DISTRIBUTION (URBAN AREA)
IMP. VALLEY COMMUNITY COLLEGE DIST.
CONDUIT LAYOUT

APPROVED: *AD* DATE: 4/9/10

CHECKED BY: *EB* 4/9/2021

DESIGN'D: E.B. DRAWN BY: S.A. DATE: 4-9-2021

FILE NAME: 60126554

REV.#	PG#	DATE	BY	DESCRIPTION

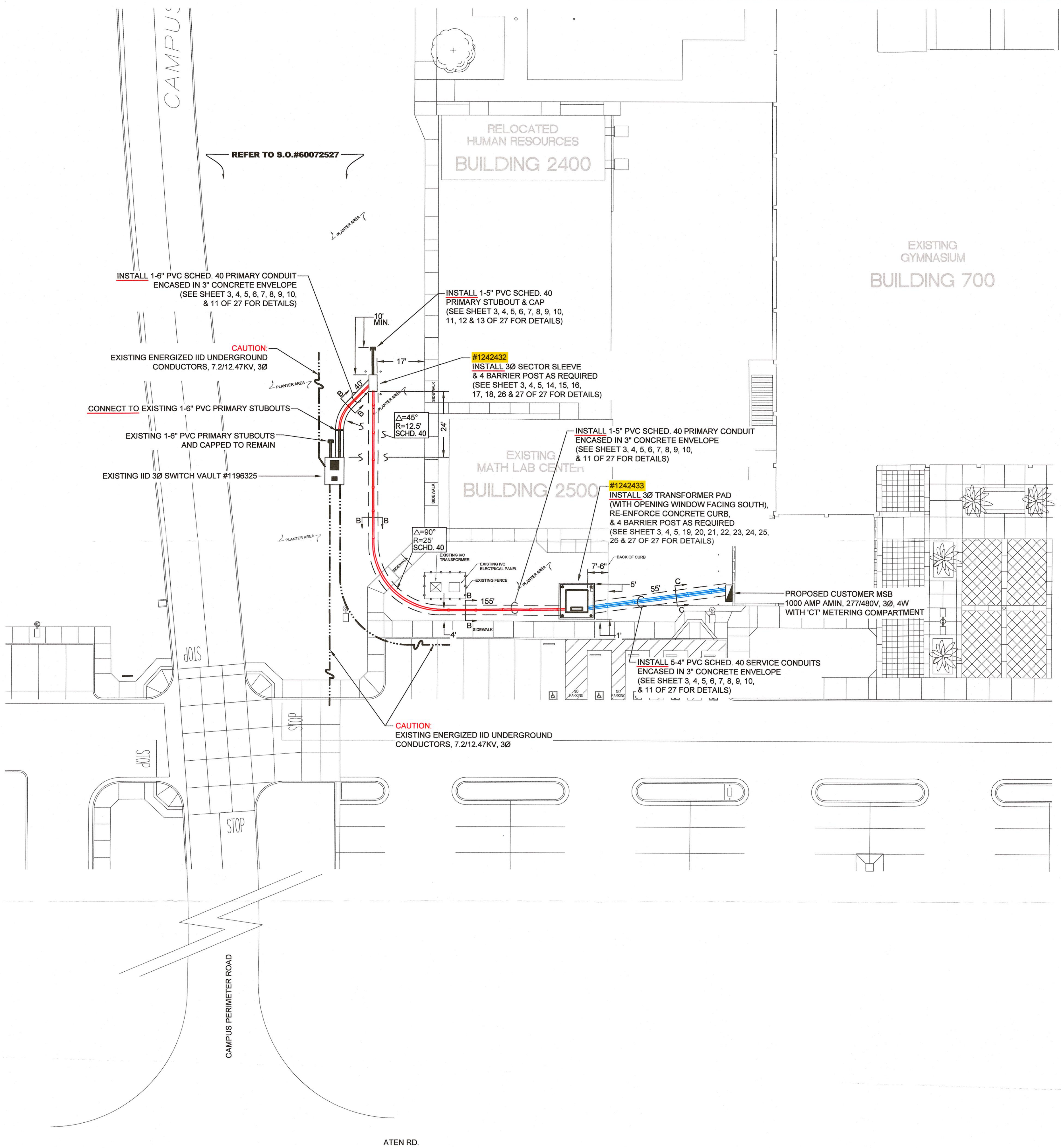
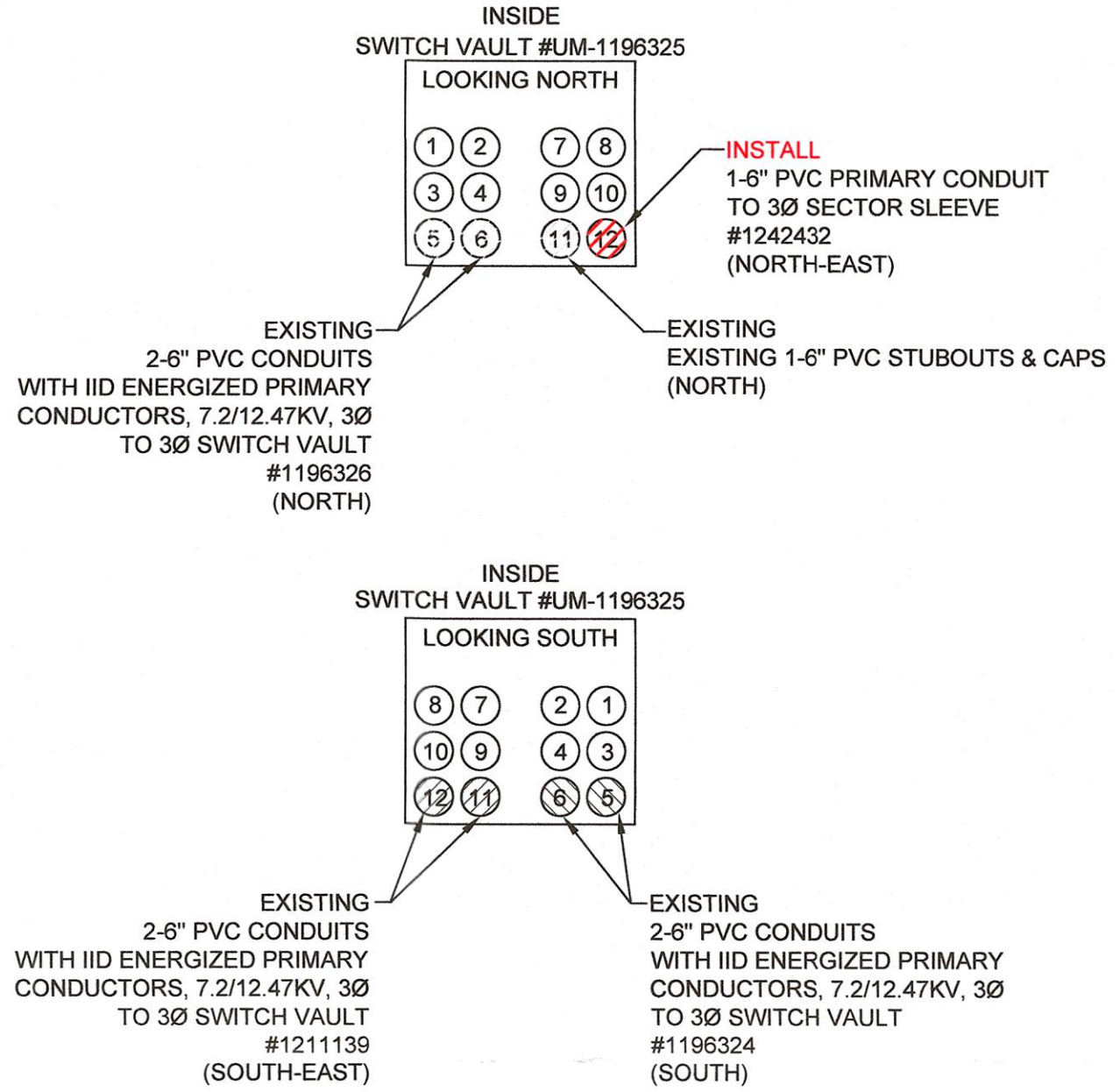



IMPERIAL IRRIGATION DISTRICT

Customer Project Development • 333 S. Waterman Ave • El Centro, CA 92243

NOTE: CONTACT IID AT (760) 482-3300 TO SCHEDULE A PRE-CONSTRUCTION MEETING BEFORE PROJECT TRENCHING GETS UNDERWAY AND TO REVIEW U.G. INSPECTION SCHEDULE.

UNDERGROUND INSPECTION PROCESS

1. Pre -construction meeting with Electrical Contractor.
 - A. IID Inspector and Contractor to meet **BEFORE** any construction or excavating. IID Inspector will explain and/or highlight general installation notes according to the job. IID Inspector will also answer any questions the contractor has to avoid any delays in the future.
2. Trench depth and inspection of primary or secondary conduit installation.
 - A. Verify minimum primary and secondary trench depth is met.
 - B. Verify correct conduit(s) is being used, schedule 40 for below ground and schedule 80 for above ground use.
 - C. Verify approved diameter of conduit is being installed; see Contractor's Notes (drawing).
 - D. Verify spacing between conduits (3") is met and spacers are installed at every six feet.
3. Concrete encasement of conduit(s) where required or 12 inches of "native soil or sand."
 - A. Concrete encasement is required for street crossings, parking lots, driveways, and sidewalks. Encasement to be three sack mix at 2,000 p.s.i sand slurry. When these applications are not the case, then two sack slurry mix to be used.
 - B. Verify there is a three-inch envelope of encasement all around conduit (spacers must be installed prior to encasing)
4. Caution tape over encasement or 12 inch of backfill.
5. Cadweld connection of ground wire to ground rod located at the bottom of the trench for all transformer precast pads, single phase sector precast pads, and three phase sector sleeves.
 - A. Verify ground rods are 5/8" x 10'
 - B. Verify copper strand is 2/0 wire.
6. Backfill of trench and compaction.
 - A. Backfill of trench shall or excavated areas must be a minimum of 90% compaction.



IMPERIAL IRRIGATION DISTRICT

Customer Project Development • 333 S. Waterman Ave • El Centro, CA 92243

Continued:

7. Stub out markers are installed where applicable.
8. Backfill of all transformer precast pads, single phase sector precast pads, and sector sleeve locations.
9. Verification of compaction test results for all transformer precast pads and all single phase sector precast pads.
 - A. Location of all transformer precast pad and single phase sector precast pads to be a compaction of 90% minimum by contractor/developer.
 - B. Compaction will be performed at a minimum of 2' beyond proposed transformer and single phase sector precast pads on all four sides.
 - C. Contractor to contact IID Inspector after compaction has been completed. IID Inspector must pass visual compaction prior to compaction test.
 - D. After IID Inspector passes compaction by contractor, the contractor will obtain a compaction test.
 - a) **NOTE:** A maximum of 1/2" of sand fill will be approved for leveling of compaction area. If the sand fill exceeds the maximum requirement, the IID Inspector will fail the compaction.
 - E. All transformer and single phase sector precast pads will not be installed until compaction test report has been received and reviewed by IID Inspector.
 - F. After compaction test report is reviewed by IID Inspector, the inspector must be present when contractor installs all transformer precast pads.
 - a) **NOTE:** After compaction test has been reviewed by IID Inspector, transformer precast pad must be installed within 24 hours. If transformer precast pad is not installed within allotted time, IID will require a re-test of compaction from contractor/developer.
10. Installation of any concrete vault, transformer precast pad, sector sleeve or secondary pullbox.
 - A. Verify there are no visible cracks on all transformer precast pads, single phase sector precast pads, concrete vaults, and sector sleeves.
 - B. Verify vaults, all transformer precast pads, sector sleeves, and secondary pullboxes are installed above their appropriate final grade (See Developers Energy Planning Guide).



IMPERIAL IRRIGATION DISTRICT

Customer Project Development • 333 S. Waterman Ave • El Centro, CA 92243

Continued:

11. Framing and pouring concrete pad for customer meter panel.
12. Installation of customer meter panel.
13. Barrier post installation (when applicable).
 - A. Verify footing is 36" in depth and 18" in diameter.
 - B. Barrier post is set 30" below finish grade.
 - C. Barrier post is 4" steel pipe.
 - D. Barrier post is painted High Visibility Yellow.
14. Final: Cold and/or hot mandrel inspection.

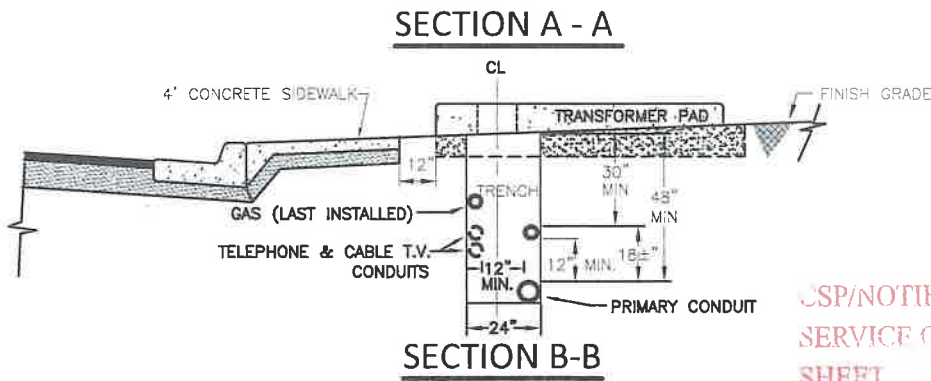
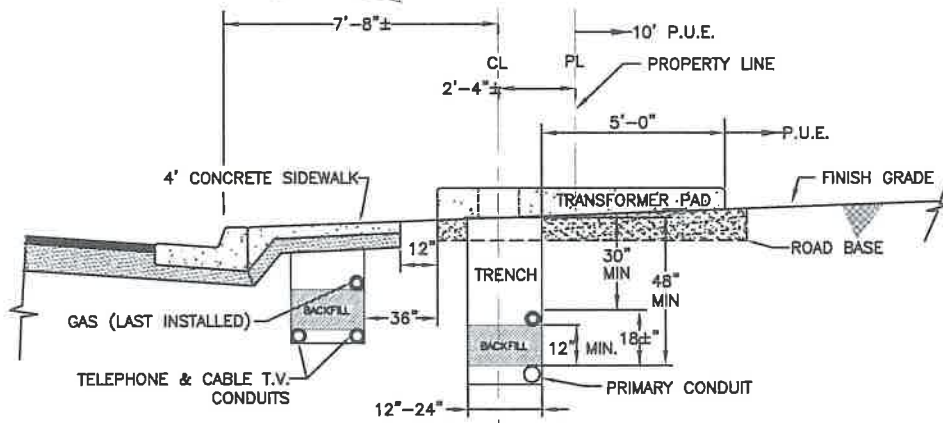
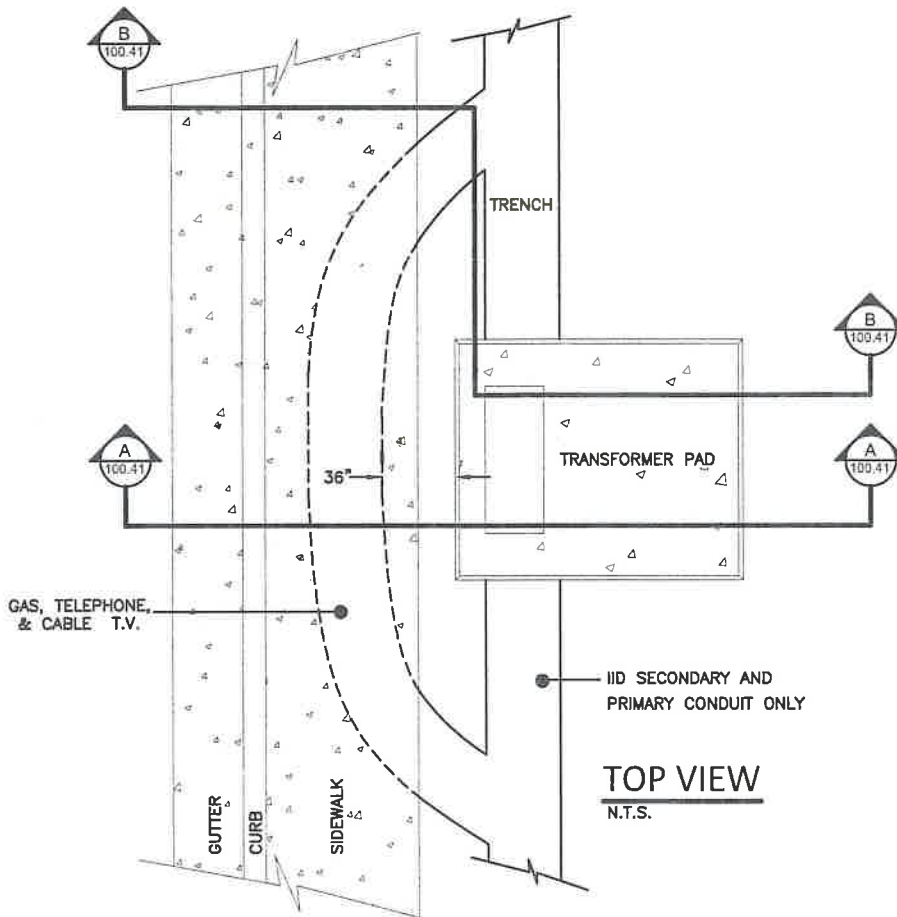

CSP/NOTIFICATION # 4029692
SERVICE ORDER # 60126554
SHEET 6 OF 27

DRAWN BY			JOINT UTILITY (GAS INCLUDED)-TRENCH DETAIL, CURB, GUTTER, SIDEWALK, 10FT. PARKWAY WITH 10 FT. P.U.E.
REVIEWED			
APPROVED			
REVISION	REV 6		
DATE	12-31-2013		

100.41

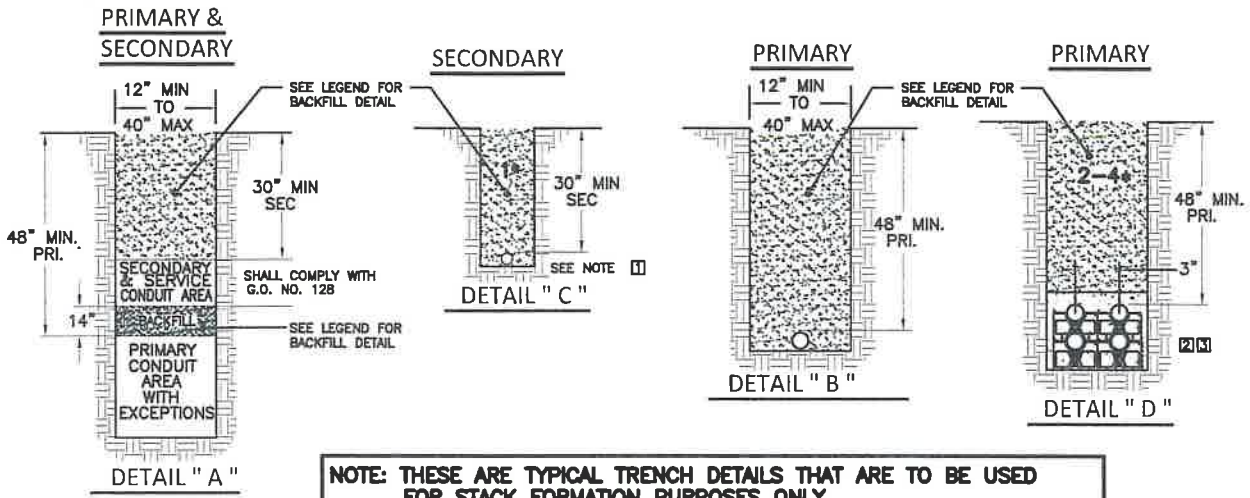

NOTE: THESE ARE TYPICAL TRENCH DETAILS THAT ARE TO BE USED FOR STACK FORMATION PURPOSES ONLY. MIN. DEPTH WILL BE (PRI. 48", SEC. 30") AT ANY DEPTH.

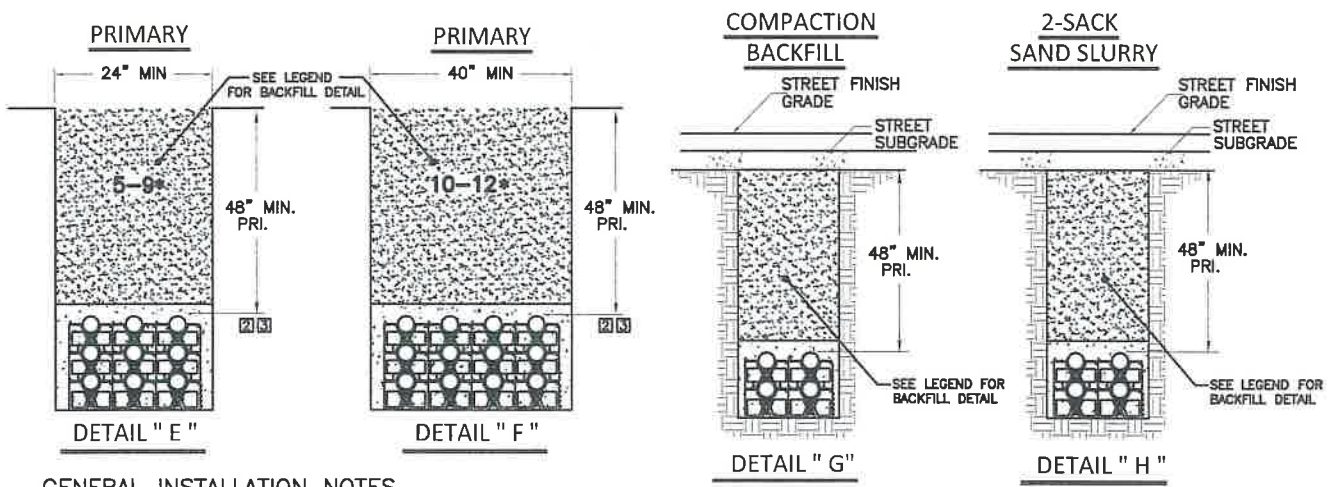

GENERAL INSTALLATION NOTES

1. USE PLASTIC SPACERS THAT PROVIDE 3" SEPARATION.
2. PLASTIC SPACERS SHALL BE USED ON CONDUIT RUNS TO BE CONCRETE ENCASED BOTH AS SINGLE OR BANKED INSTALLATIONS AND ON DUCT BANKS NOT ENCASED. (REFER TO NOTE 3.48).
3. CONDUIT RUNS SHALL NOT CROSS EACH OTHER WHEN ON THE SAME LEVEL AND/OR PLANE. (REFER NOTE 3.23)
4. THE MAXIMUM OBTAINABLE SEPARATION BETWEEN POWER FACILITIES AND ALL OTHER SUBSTRUCTURES SHALL BE MAINTAINED AT ALL TIMES, 12" MIN. WHEN PARALLELING AND 12" MIN. WHEN CROSSING ENCASED IN CONCRETE.
5. WHEN CONCRETE ENCASEMENT IS SPECIFIED ON THE JOB, ENCASEMENT SHALL BE A 3 SACK MIX (2000 PI) WITH SAND SLURRY WILL BE USED BELOW STREETS, PARKING LOTS, DRIVEWAYS, AND SIDEWALKS. WHEN STREETS, PARKING LOTS, DRIVEWAYS, AND SIDEWALKS DO NOT EXIST OVER THE DUCT SYSTEM, A 2 SACK SAND SLURRY MAY BE USED. (REFER TO NOTES 3.18, 3.19).
6. ENCASE IN CONCRETE 3" ENVELOPE WHERE REQUIRED. SEE CONDUIT LAYOUT SHEETS (JOB COPY) FOR LOCATION OF CONCRETE TRENCHES.
7. LINE GUARD TAPE REQUIRED IN ALL TRENCHES. (REFER TO NOTE 3.46 STANDARD100.5)

*IDENTIFY # OF CONDUITS

LEGEND

- CONDUIT
- 3 SACK MIX SAND SLURRY
- 2 SACK SAND SLURRY
- 90% COMPACTION BACKFILL (BACKFILL TO BE NATIVE SOIL OR CALTRANS CLASS 2 AGGREGATE BASE OR CRUSHER FINE WITH 3/8 INCH ROCK).

IMPERIAL IRRIGATION DISTRICT		CSP/NOTIFICATION # 4029692
		SERVICE ORDER # 60126554
		SHEET 7 OF 27
TRENCH DETAILS		
DRAWN BY	<i>JK</i>	
REVIEWED	<i>MS</i>	
APPROVED	<i>MS</i>	
REVISION	REV 6	
DATE	9-27-2016	100.3

3.32 All conduits shall meet and/or exceed UL-651 and/or NEMA TC-2. All conduits shall be:

3.32.1 Schedule 40 for below ground installation:

3.32.1.1 PVC Heavy Wall

3.32.1.2 PVC Cellular Core

3.32.2 Schedule 80 above ground installation:

3.32.2.1 PVC Heavy Wall

3.33 All conduit sweeps shall meet and/or exceed UL-651 and/or NEMA TC-3.

3.34 Conduit sweeps in duct runs shall not have less than a 12 feet 6 inches (12.5') horizontal radius unless shown otherwise on the Contractor Notes. (See Radius Index 3.33.1 (Horizontal) Table 4).

3.34.1 Table 4 Conduit Radius Index – Horizontal

CONDUIT RADIUS INDEX (HORIZONTAL) Table 4			
PRIMARY			
CONDUIT DIA.	RADIUS	CONDUCTOR SIZE	PVC SCHEDULE
4"	12.5' Radius	1-1/0 Conductor	40
5"	12.5' Radius	3-1/0 Conductors	40
6"	25' Radius Typical	3-750 MCM Conductors	40
6"	*50' Radius as Specified	3-750 MCM Conductors	40

*Contact your IID Customer Service Project Manager for instructions

3.35 Conduit sweeps in vertical runs (pole risers and equipment risers) shall be installed in accordance with Table 5, (3.37.1 Riser Sweep Radius – Vertical).

3.36 All 2 inch and 3 inch service and/or secondary conduit (vertical) risers which enter buildings, service panels, secondary boxes, transformer pads, meter panels, etc., shall have a minimum 2 foot radius (24"), see Table 5, (3.37.1 Riser Sweep Radius – Vertical).

3.37 All 4 inch primary conduit (vertical) risers which enter transformer pads, primary metering panels, underground switch gear panels and pole risers, shall have a 4 foot (48") Radius for 4 inch duct, see Table 5, (3.37.1 Riser Sweep Radius – Vertical).

3.38 All 5 inch and 6 inch primary conduit risers which enter transformer pads, primary metering panels, underground switch gear panels and pole risers, shall have a minimum of 4 foot (48") radius for 5 inch ducts, and 5 foot radius (60") for 6 inch ducts, see Table 5, (3.37.1 Riser Sweep Radius – Vertical). Contact your IID Customer Project Development Services for further instructions or questions.

CSP/NOTIFICATION # 4029692
 SERVICE ORDER # 60126554
 SHEET 8 OF 27

3.38.1 Table 5 Riser Sweep Radius – Vertical

RISER SWEEP RADIUS INDEX (VERTICAL) TABLE 5						
SECONDARY	Radius	Pole Riser	Equip. Riser	Trans. Pad	Secondary	Meter Panels
Conduit Dia.		PVC SCH	PVC SCH	PVC SCH	PVC SCH	PVC SCH
2"	24" Radius	N/A	40	40	40	40
3"	36" Radius	80	40	40	40	40
4"	*36"-48" Radius	80	40	40	40	40
PRIMARY	Radius	Pole Riser	Equip. Riser	Trans. Pad	Secondary	Meter Panels
Conduit Dia.		PVC SCH	PVC SCH	PVC SCH	PVC SCH	PVC SCH
4"	48" Radius	80	40	40	N/A	N/A
5"	*48"-60" Radius	80	40	40	N/A	N/A
6"	60" Radius	80	N/A	N/A	N/A	N/A

*Contact your IID Customer Service Project Manager for instructions.

N/A = Not Applicable

3.39 The installation of the conduit system will be conducted by a single contractor or other entity to give the project continuity, reducing the possibility of deviations from the G.O. 128 regulations, Authority having jurisdiction, and IID standards. Developer/Contractor will accept the most strict or highest requirements from the entities mentioned above.

3.40 Marking Tape over Conduits:

3.40.1 Contractor shall install 2 inch line guard III tape, red in color with black lettering "**CAUTION BURIED ELECTRIC LINE BELOW**" (See 3.46, Standard 100.5)

3.40.2 Contractor will install tape 12 inches (1') above the power conduits. When conduit(s) is/are encased in concrete, Developer/Contractor shall back fill with compacted (90%) native soil to meet the 12 inch (1') requirement. (See 3.46, Standard 100.5)

3.41 Mandrel

3.41.1 The installation contractor shall mandrel all primary ducts and secondary service ducts. IID shall provide the mandrel and the IID inspector for the mandrel process. Refer to 3.41.1 Pulling Rope, Table 8 Conduit rope/Measured Rope Requirements for Primary Pulls. Inspection field check schedules are subject to a minimum 48 hour advance notice and are by appointment only; Imperial (760) 482-3300; La Quinta (760) 398-5828

3.41.2 IID Inspector will conduct a field check prior to mandrel test to ensure IID structures are:

3.41.2.1 Not damaged

3.41.2.2 Clear of debris

3.41.2.3 No obstructions to IID structures (accessibility)

3.41.3 If mandrel is requested from IID structure to meter panel, IID Inspector will field check the following:

CSP/NOTIFICATION # 4029692
 SERVICE ORDER # 60126554
 SHEET 9 OF 27

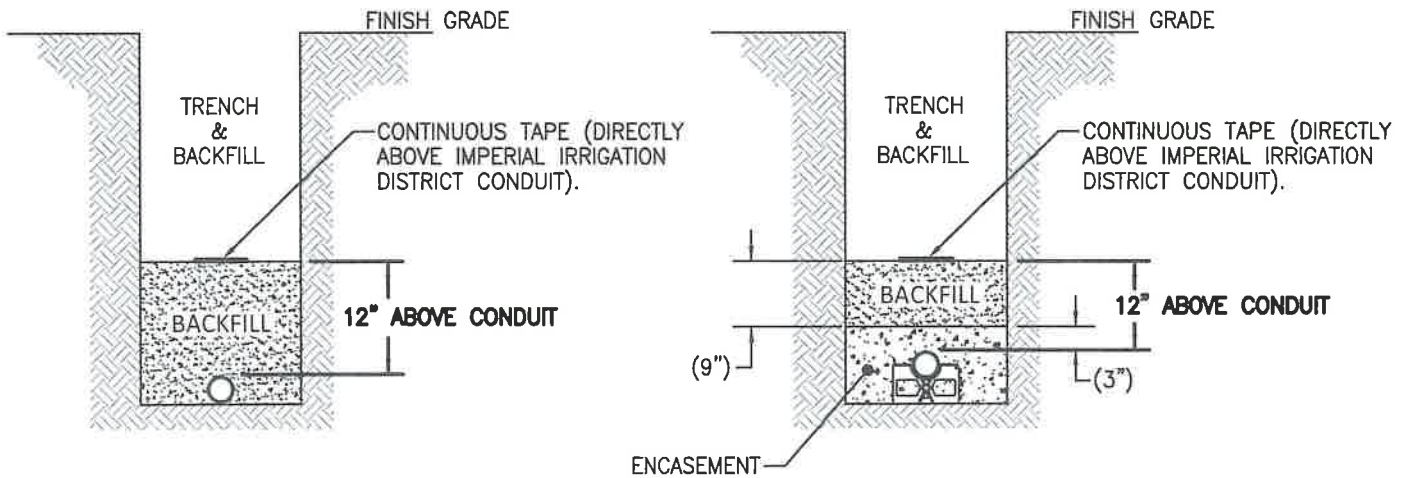
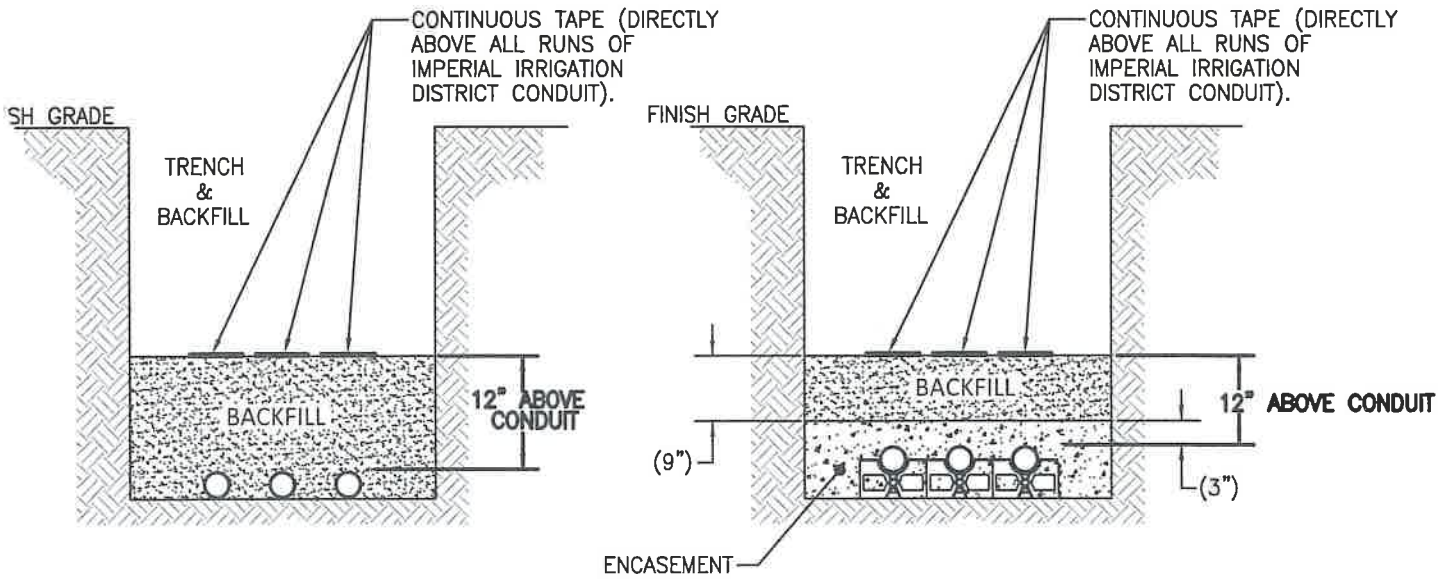

**TYPICAL TRENCH DETAIL
W/LINEGUARD III TAPE OR EQUIVALENT**

NOTES:

1. INSTALL LINE GUARD III TAPE (RED, MINIMUM 2" WIDE). TAPE TO BE FURNISHED & INSTALLED BY CONTRACTOR AND SHALL READ: **"CAUTION: BURIED ELECTRIC LINE BELOW"**.

2. TAPE WILL BE INSTALLED 12" ABOVE HIGHEST PRIMARY OR SECONDARY IMPERIAL IRRIGATION DISTRICT CONDUIT TRENCH.

CSP/NOTIFICATION # 4029692
SERVICE ORDER # 60126554
SHEET 10 OF 27

IMPERIAL IRRIGATION DISTRICT		 100.5
DRAWN BY	<i>J</i>	
REVIEWED	<i>MS</i>	
APPROVED	<i>MS</i>	
REVISION	REV 5	
DATE	12-31-2013	LINE GUARD III TAPE

3.47 All conduit spacers shall be made of polystyrene or high impact polymer material; see representation (A) below, (Refer to 3.49 Table 6 for spacer clearances). Spacers shall provide the conduit separation shown in 3.49 Table 6 below.

3.48 Conduit spacers will be installed every 6 feet (72").



Spacer representation (A) (See 3.47)

3.49 Table 6 Spacers Clearances

TABLE 6 CONDUIT SPACER CLEARANCES					
CONDUIT SIZE	DUCT TO DUCT SEPARATION		CLEARANCE TRENCH TO CONDUIT		
	HORIZONTAL	VERTICAL	SIDE	BOTTOM	TOP
3"	3"	3"	3"	3"	3"
4"	3"	3"	3"	3"	3"
5"	3"	3"	3"	3"	3"
6"	3"	3"	3"	3"	3"

CSP/NOTIFICATION # 4029692
 SERVICE ORDER # 60126554
 SHEET: 11 of 27

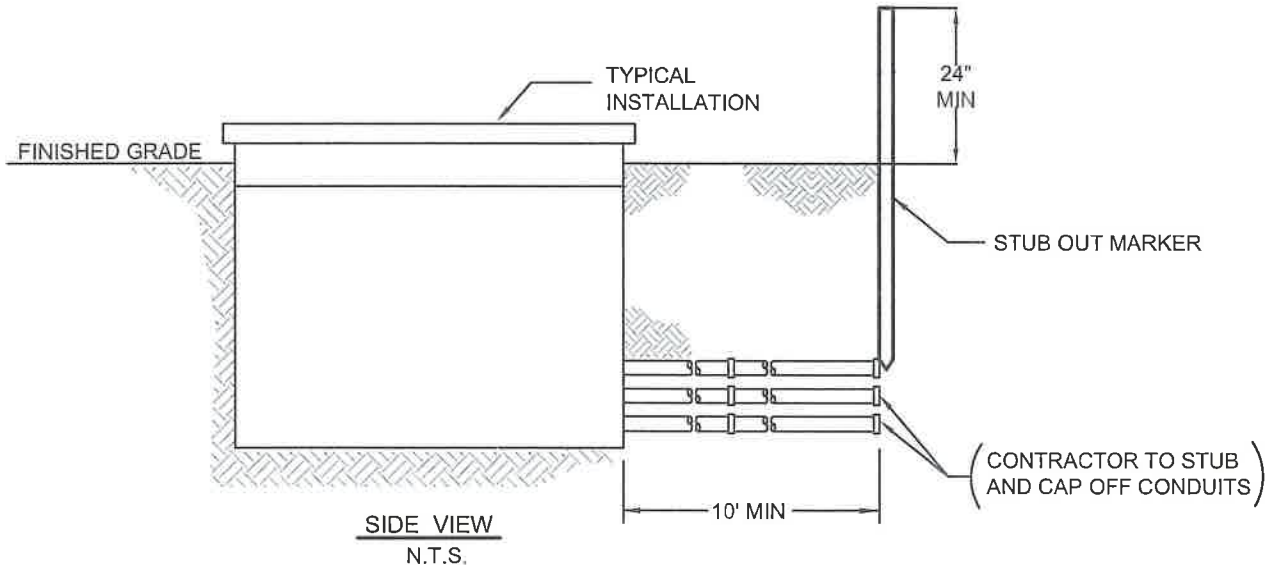

NOTES:

1. ENCASEMENT SHALL BEGIN 10' MINIMUM FROM VAULT.
2. NO CONCRETE TO BE POURED WITHIN 10' OF ANY CONDUIT ENTRANCE OR EXIT WALL OF VAULT.

CSP/NOTIFICATION # **4029692**
 SERVICE ORDER # **60126554**
 SHEET **12** OF **27**

IMPERIAL IRRIGATION DISTRICT		 100.14	STUB OUT MARKER DETAIL
DRAWN BY	<i>JK</i>		
REVIEWED	<i>MS</i>		
APPROVED	<i>MS</i>		
REVISION	REV 8		
DATE	9-26-2016		

3.50 Contractor shall obtain and install stub out markers comparable to the stub out marker indicated in Table 9, (see 3.51).



Stub out Marker
66" x 4.25"



Front View
Top Portion



Back View
Top Portion

3.51 Stub out conduit shall be a minimum of 10'. Refer to Contractor Notes drawing for specific Stub out lengths. (Refer 3.53 Standard 100.14, Stub out Detail).

CSP/NOTIFICATION # 4029692
SERVICE ORDER # 60126554
SHEET 13 OF 27

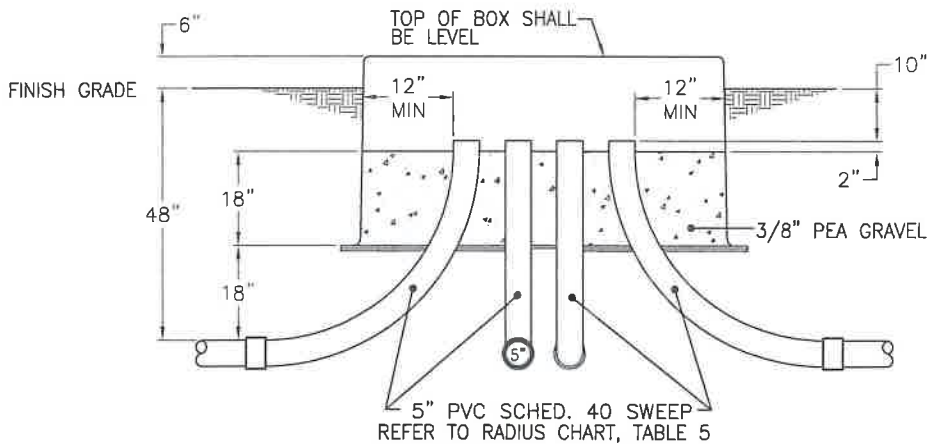
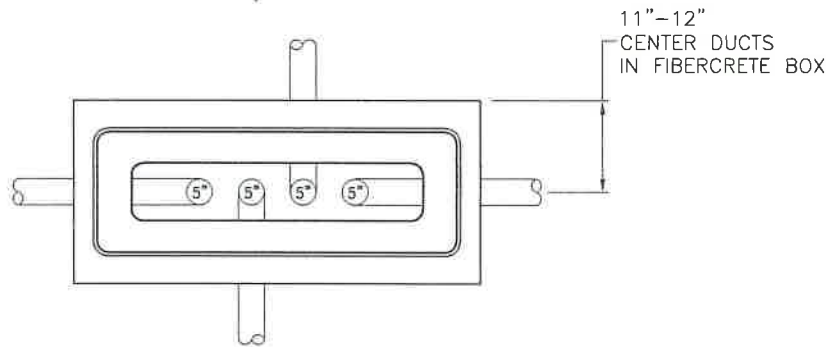
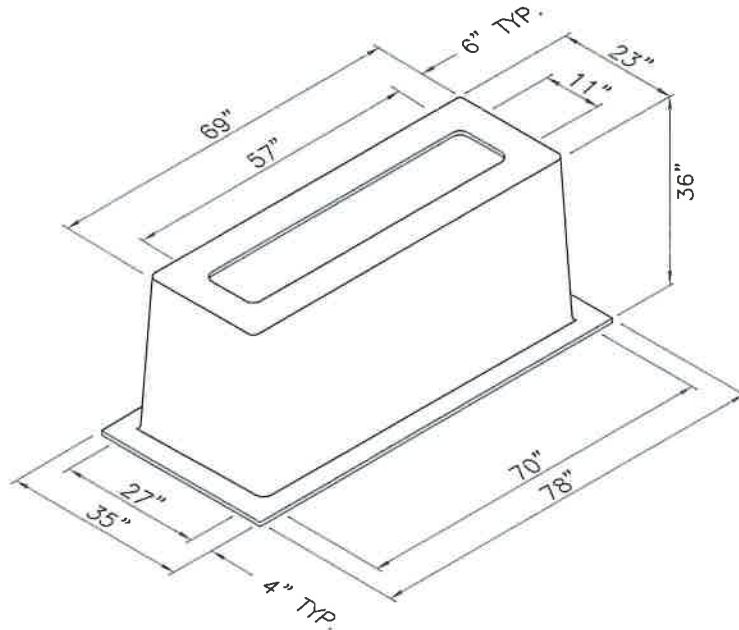

CSP/NOTIFICATION # **4029692**
 SERVICE ORDER # **60126554**
 SHEET **14** OF **27**

IMPERIAL IRRIGATION DISTRICT		 171.2	THREE PHASE SECTOR
DRAWN BY	<i>JK</i>		SLEEVE INSTALLATION DETAILS
REVIEWED	<i>MS</i>		
APPROVED	<i>MS</i>		
REVISION	REV 7		
DATE	12-19-2016		

CONSTRUCTION NOTES:

1. COMPACT ALL BACKFILL FOR EXCAVATION UNDER SECTOR SLEEVE TO 90% BEFORE FIBERCRETE BOX PAD INSTALLATION.
2. CONTRACTOR SHALL PROVIDE & INSTALL 3/8" PEA GRAVEL MATERIAL UNDERNEATH SECTOR SLEEVE, AND 18" INSIDE OF BOX FOR SUPPORT AND DRAINAGE.
3. CONTRACTOR TO PROVIDE TWO 5/8" x 10' COPPERWELD GROUND RODS PER SECTOR SLEEVE (INSALLATION BY CONTRACTOR).
4. SIZE AND NUMBER OF CONDUITS IN EACH SECTOR SLEEVE TO BE AS SHOWN ON CONDUIT LAYOUT.
5. CONDUITS NEED TO BE CENTERED IN FIBERCRETE BOX.
6. ALL PRIMARY SWEEPS TO BE PVC SCHEDULE 40, REFER TO TABLE 5 RISER SWEEP RADIUS.
7. GUARD POSTS MAY BE REQUIRED AT DISCRETION OF I.I.D. INSPECTOR.
8. ANCHORAGE TO BE SET BY I.I.D. WHEN TRANCLOSURE IS INSTALLED.
9. APPROVED MANUFACTURERS AND STRUCTURES:

MANUFACTURER	PHONE No.	STRUCTURE No.
CONCAST, INC	REXEL (760) 352-4941	FC-23-69-36-1157

CSP/NOTIFICATION # 4029692
 SERVICE ORDER # 60126554
 SHEET 15 OF 27

DRAWN BY			THREE PHASE SECTOR SLEEVE INSTALLATION DETAILS
REVIEWED			
APPROVED			
REVISION	REV 6		
DATE	12-09-2013		
		171.21	

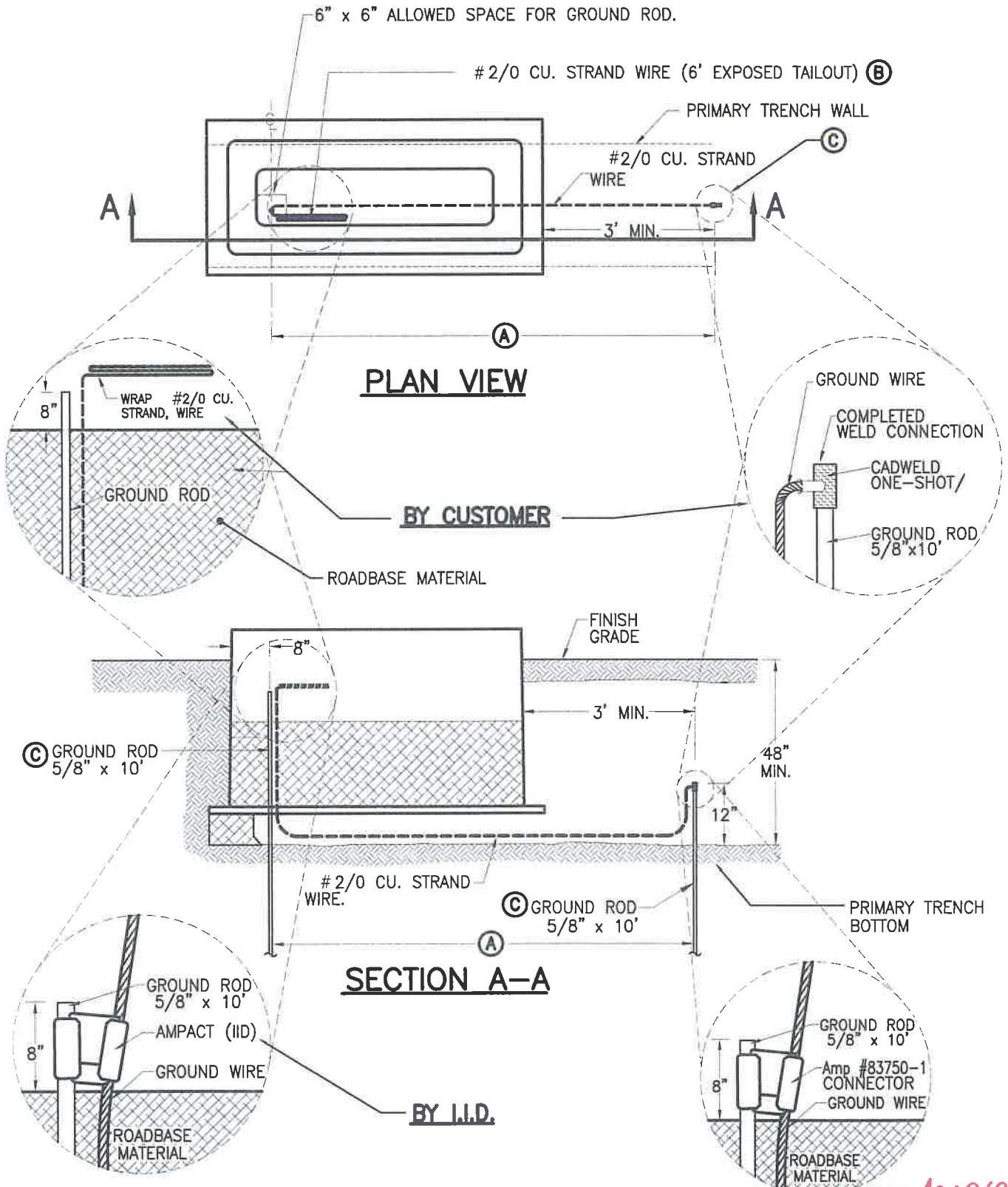

CSP/NOTIFICATION # 4029692
 SERVICE ORDER # 60126554
 SHEET 16 OF 27

IMPERIAL IRRIGATION DISTRICT		 190.5	THREE PHASE SECTOR SLEEVE GROUNDING DETAIL TO BE INSTALLED BY CONTRACTOR
DRAWN BY	<i>Jr</i>		
REVIEWED	<i>ms</i>		
APPROVED	<i>ms</i>		
REVISION	REV 7		
DATE	11-21-2016		

CONSTRUCTION NOTES:

- Ⓐ GROUND RODS TO HAVE A 6'-0" MINIMUM SEPARATION.
- Ⓑ WRAP 6' OF WIRE (EXPOSED TAILOUT)
- Ⓒ **LOCATE GROUND RODS SO THEY DO NOT TOUCH CONDUITS.** GENERAL ORDER 128 REQUIRES GROUND RODS TO BE DRIVEN.

BILL OF MATERIAL

ITEM	QTY	DESCRIPTION	STOCK No.	PAGE No.
1	1	SECTOR SLEEVE SEE STANDARD 171.2		
2	1	CADWELD, ONE-SHOT/ Amp #83750-1 CONNECTOR	40003365	
3	20'	WIRE - COPPER 00 2/0 STRAND, SOFT DRAWN BARE	40004222	
4	2	GROUND ROD, 5/8" x 10', COPPERWELD	40003814	

NOTES:

THE SERVICE TRENCH IS ON PRIVATE PROPERTY AND BELONGS TO THE CUSTOMER, THEREFORE, THE TRENCH GROUND WIRE SHOULD NOT BE INSTALLED IN THE CUSTOMER TRENCH.

CSP/NOTIFICATION # **4029692**
 SERVICE ORDER # **60126554**
 SHEET **17** OF **27**

DRAWN BY		IMPERIAL IRRIGATION DISTRICT	
REVIEWED	<i>[Signature]</i>		THREE PHASE SECTOR SLEEVE GROUNDING DETAIL TO BE INSTALLED BY CONTRACTOR
APPROVED	<i>[Signature]</i>		
REVISION	REV 7		
DATE	11-21-2016		

190.51

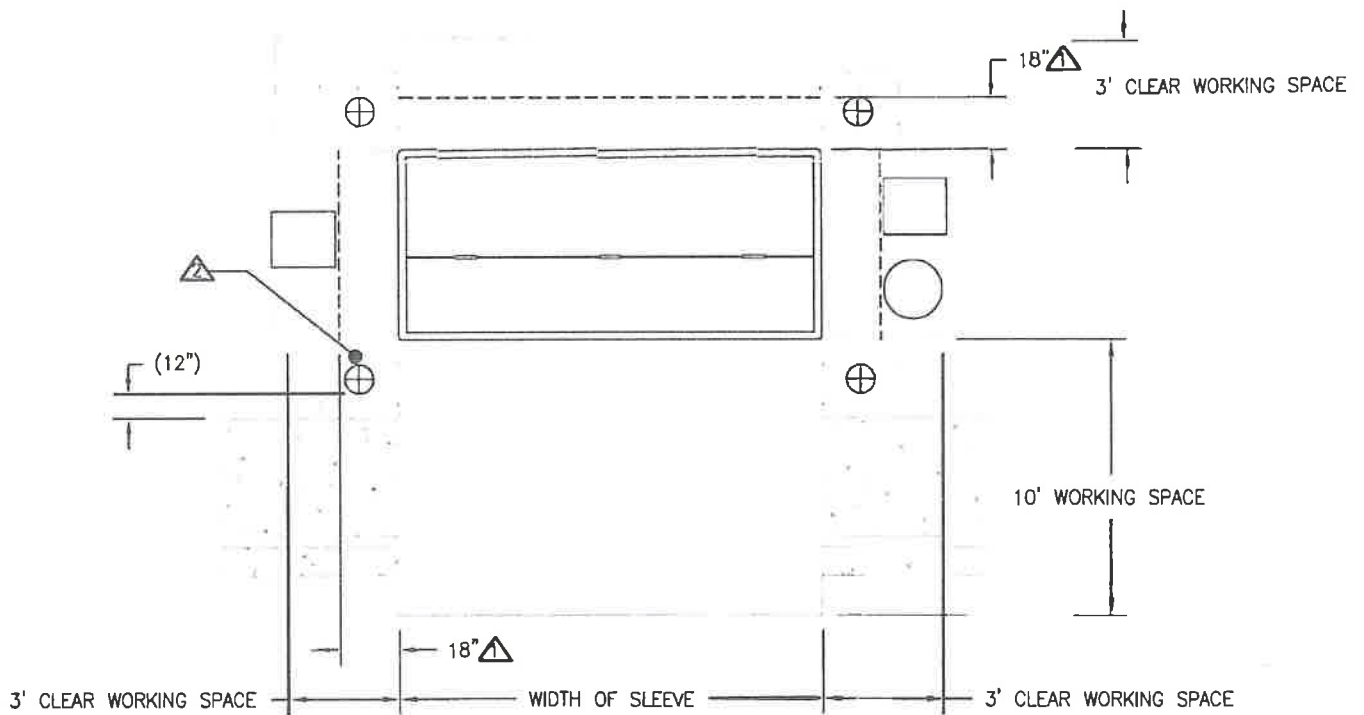
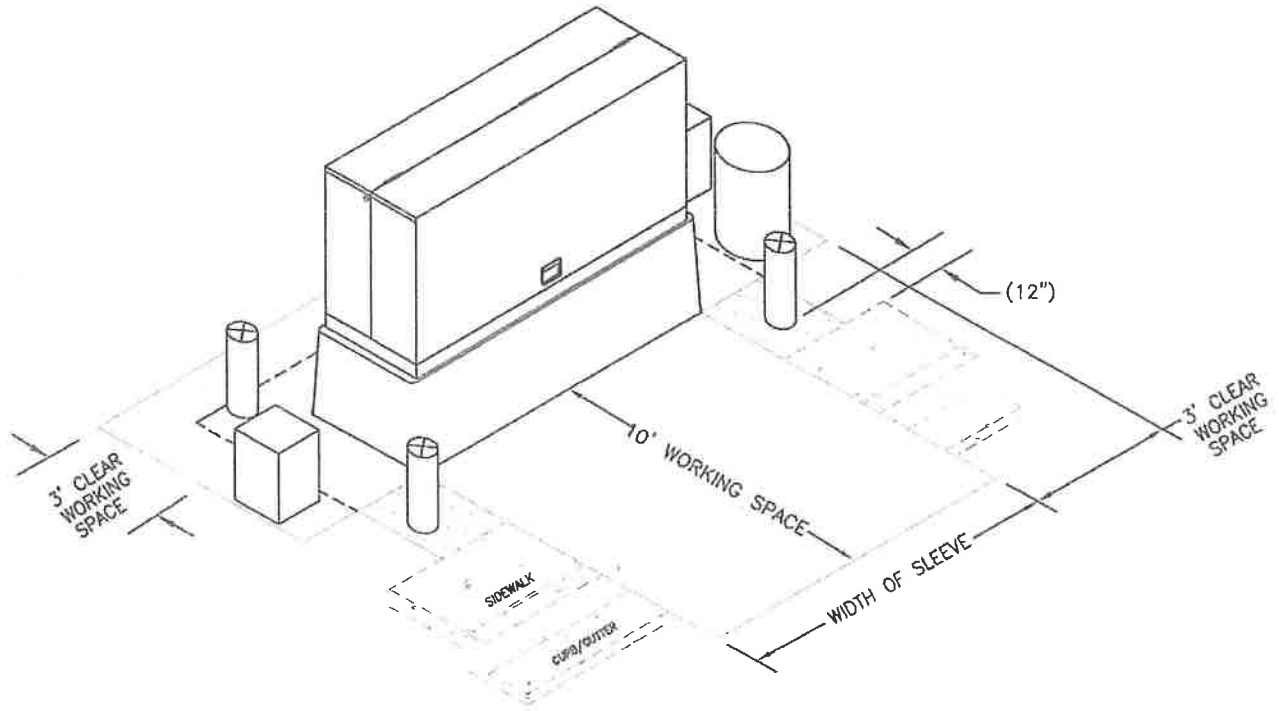

NOTES:

▲ THE PURPOSE OF THIS DRAWING IS TO ILLUSTRATE THE REQUIRED CLEARANCES FROM AN I.I.D SECTOR TO OTHER UTILITIES (18") AND MINIMUM HOT STICK CLEARANCE.

▲ WHEN BARRIER POSTS ARE REQUIRED, ALL OTHER UTILITIES TO STAY CLEAR OF AREA. (REFER TO BARRIER POST DETAIL, 181.6, SECTION 5.32.)

CSP/NOTIFICATION # 4029692
SERVICE NUMBER # 60126554

IMPERIAL IRRIGATION DISTRICT		SHEET 18 OF 27
DRAWN BY	JK	 <p>THREE - PHASE LOW PROFILE SECTOR CABINET SPATIAL REQUIREMENT WITH COMMUNICATION</p>
REVIEWED	PL	
APPROVED	MS	
REVISION	REV 3	
DATE	9-21-2020	
		202.8

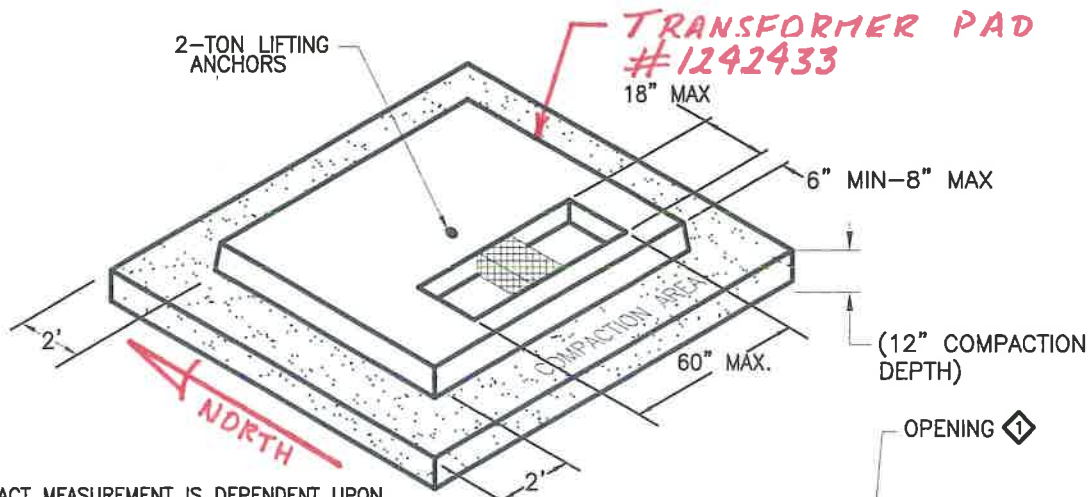

*NOTE: EXACT MEASUREMENT IS DEPENDENT UPON MANUFACTURER SPECIFICATIONS. SEE STANDARD 137.1, CONSTRUCTION NOTE 2. APPROVED MANUFACTURERS AND STRUCTURERS.

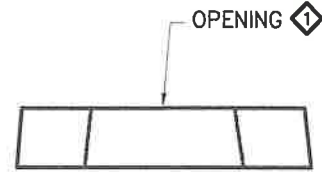

FRONT VIEW
N.T.S

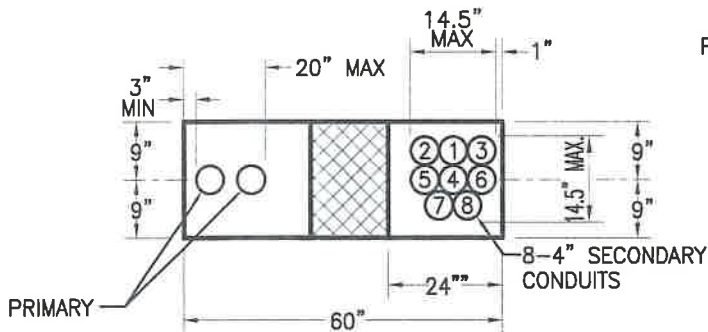
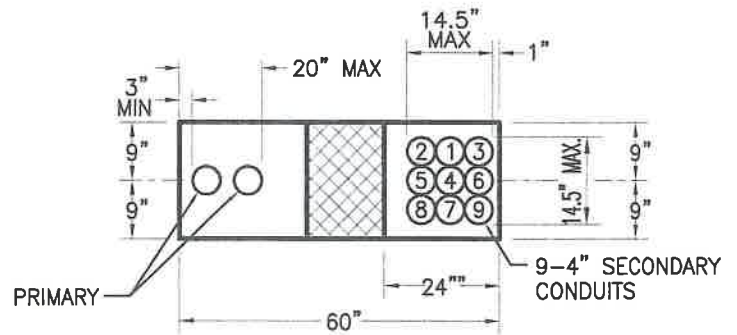
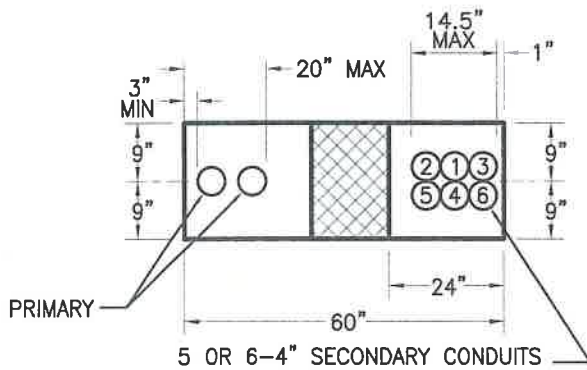
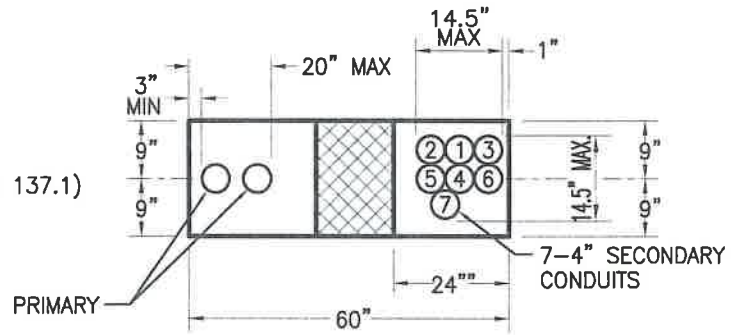
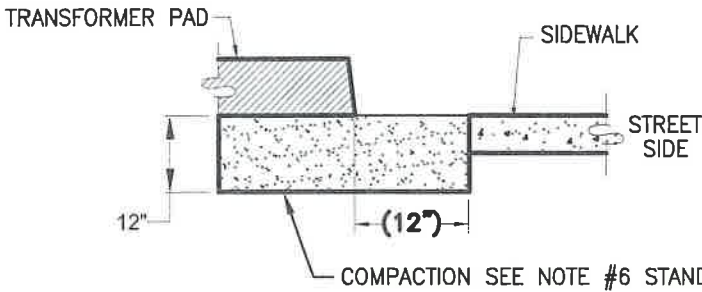

SHADED AREA TO BE CLEAR OF ALL CONDUIT

NOTE:

◊ WINDOW OPENING ON TOP OF PAD IS SLIGHTLY SMALLER THAN BOTTOM OPENING A RESULT OF FORM CONSTRUCTION

CSP/NOTIFICATION # 4029692
SERVICE ORDER # 60126554

IMPERIAL IRRIGATION DISTRICT		SERVICE ORDER # 60126554
DRAWN BY	<i>JK</i>	PRECAST CONCRETE PAD DETAIL FOR THREE-PHASE TRANSFORMERS 750KVA TO 2500KVA
REVIEWED	<i>MS</i>	
APPROVED	<i>MS</i>	
REVISION	REV 7	
DATE	9-27-2016	

CONSTRUCTION NOTES:

1. A PRECAST CONCRETE PAD SHALL BE USED.
2. APPROVED MANUFACTURERS AND STRUCTURES:

750KV - 2500 KV TRANSFORMER PAD			
MANUFACTURER	PHONE No.	STRUCTURE No.	DIMENSIONS FRONT/SIDE/THICKNESS
SUPERIOR READY MIX	(760)352-4341	3427HLR	96"(F) X 96"(S) X 8"(T)
JENSON PRECAST	1-800-257-6100	9696-T8-25	96"(F) X 96"(S) X 8"(T)
OLD CASTLE	1-800-626-3860	IID-9696-08P	96"(F) X 96"(S) X 8"(T)

(F) = FRONT (S) = SIDE (T) = THICKNESS

3. CONTRACTOR TO PROVIDE TWO 5/8"x 10' COPPERWELD GROUND RODS PER PAD (INSTALLATION BY CONTRACTOR.)
4. SIZE AND NUMBER OF CONDUITS IN EACH PAD TO BE AS SHOWN ON CONDUIT LAYOUT.
5. ANCHORAGE TO BE SET BY I.I.D. WHEN TRANSFORMER IS INSTALLED.
6. CONTRACTOR SHALL PROVIDE & INSTALL 12" OF CLASS 2 AGGREGATE ROAD BASE MATERIAL OR CRUSHER FINES WITH 3/8" ROCKS UNDERNEATH TRANSFORMER PAD, AND COMPACT ALL ROAD BASE UNDERNEATH TRANSFORMER PAD TO A MINIMUM COMPACTION OF 90%. SEE STANDARD 135. SECTION 3, 3.4.
7. CONDUITS TO TERMINATE 1" ABOVE TOP OF TRANSFORMER PAD.

CSP/NOTIFICATION # 4029692
 SERVICE ORDER # 60126554
 SHEET 20 OF 27

IMPERIAL IRRIGATION DISTRICT			PRECAST CONCRETE PAD DETAIL FOR THREE-PHASE TRANSFORMERS 750KVA TO 2500KVA
DRAWN BY	<i>JK</i>		
REVIEWED	<i>MS</i>		
APPROVED	<i>MS</i>		
REVISION	REV 8		
DATE	9-27-2016	137.1	

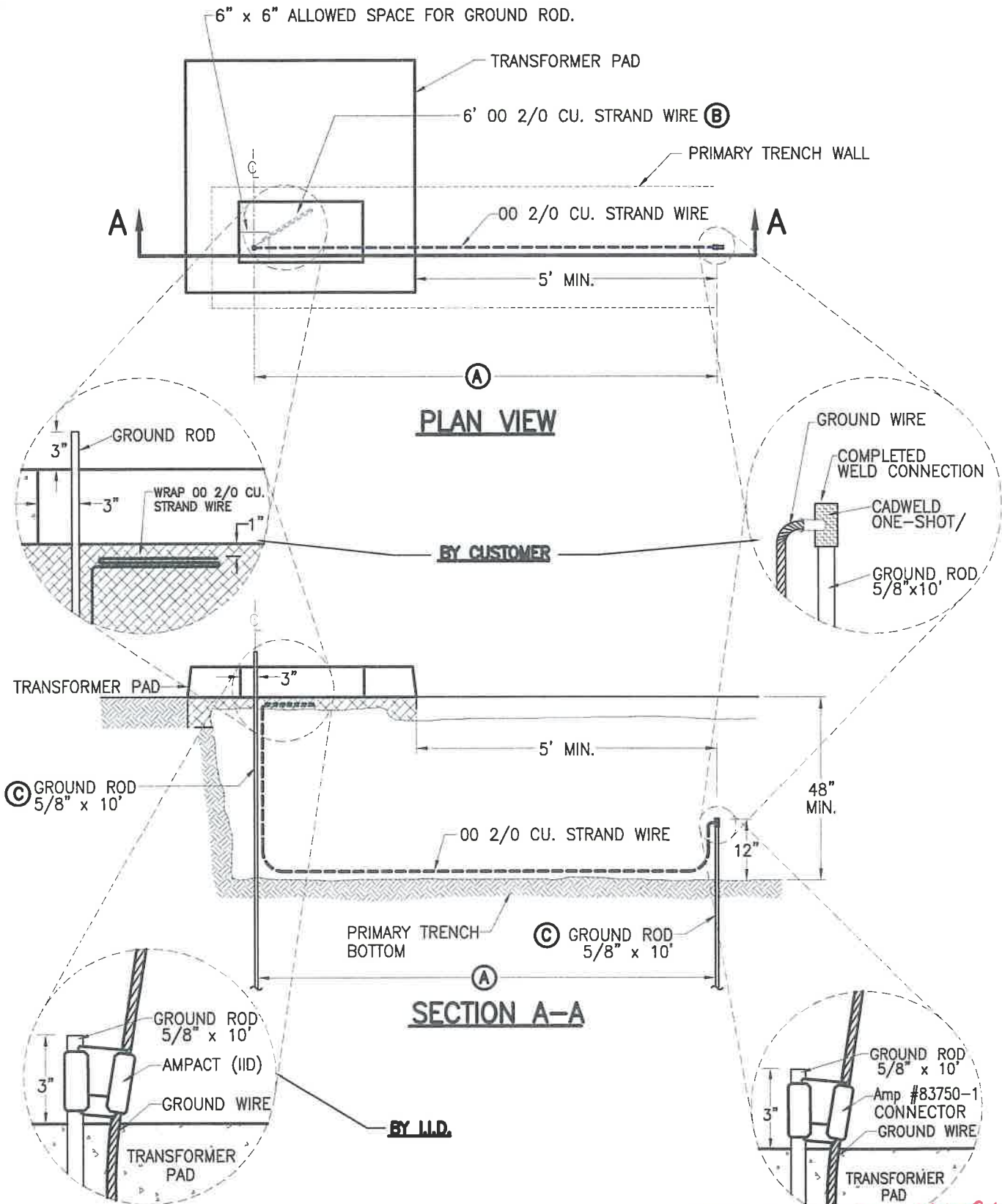

CSP/NOTIFICATION # 4029692
 SERVICE ORDER # 60126554
 SHEET 21 OF 27

IMPERIAL IRRIGATION DISTRICT		 190.3	TRENCH GROUND WIRE FOR THREE PHASE TRANSFORMER PADS TO BE INSTALLED BY CONTRACTOR
DRAWN BY	<i>js</i>		
REVIEWED	<i>-202</i>		
APPROVED	<i>ms</i>		
REVISION	REV 8		
DATE	11-21-2016		

CONSTRUCTION NOTES:

- Ⓐ GROUND RODS TO HAVE A 6'-0" MINIMUM SEPARATION.
- Ⓑ WRAP 6' OF WIRE (NOT EXPOSED) 1" UNDERGROUND NEXT TO GROUND ROD.
- Ⓒ **LOCATE GROUND RODS SO THEY DO NOT TOUCH CONDUITS.** GENERAL ORDER 128 REQUIRES GROUND RODS TO BE DRIVEN.

BILL OF MATERIAL

ITEM	QTY	DESCRIPTION	STOCK No.	PAGE No.
1	1	CONCRETE PAD, SEE STANDARD 136 THRU 137		
2	1	CADWELD, ONE-SHOT/Amp CONNECTOR #83750-1	40003365	
3	20'	WIRE - COPPER 00 2/0 STRAND, SOFT DRAWN BARE	40004222	
4	2	GROUND ROD, 5/8" x 10', COPPERWELD	40003814	

NOTES:

THE SERVICE TRENCH IS ON PRIVATE PROPERTY AND BELONGS TO THE CUSTOMER, THEREFORE, THE TRENCH GROUND WIRE SHOULD ALWAYS BE INSTALLED IN THE PRIMARY TRENCH.

CSP/NOTIFICATION # **4029692**
 SERVICE ORDER # **60126554**
 SHEET: **22** of **27**

DRAWN BY		IMPERIAL IRRIGATION DISTRICT	
REVIEWED	<i>MS</i>		TRENCH GROUND WIRE FOR THREE PHASE TRANSFORMERS PAD TO BE INSTALLED BY CUSTOMER
APPROVED	<i>MS</i>		
REVISION	REV 7		
DATE	11-21-2016		
		190.31	

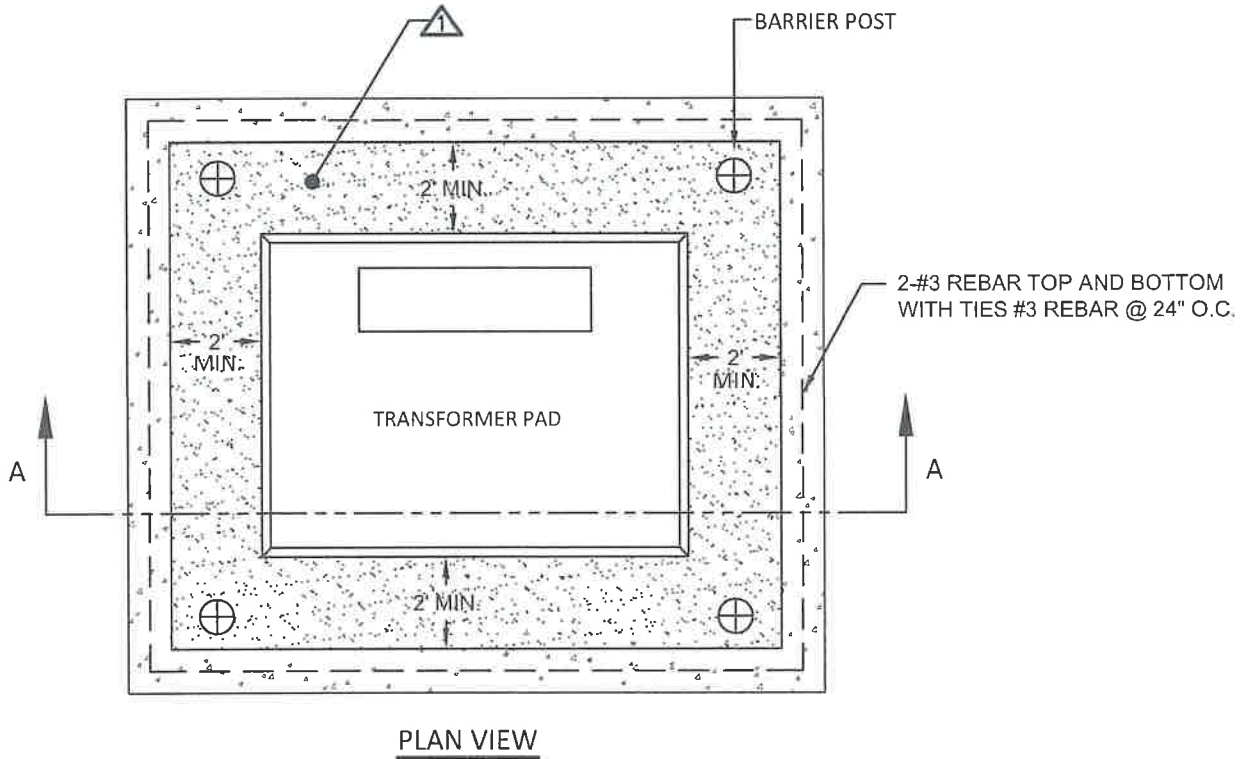
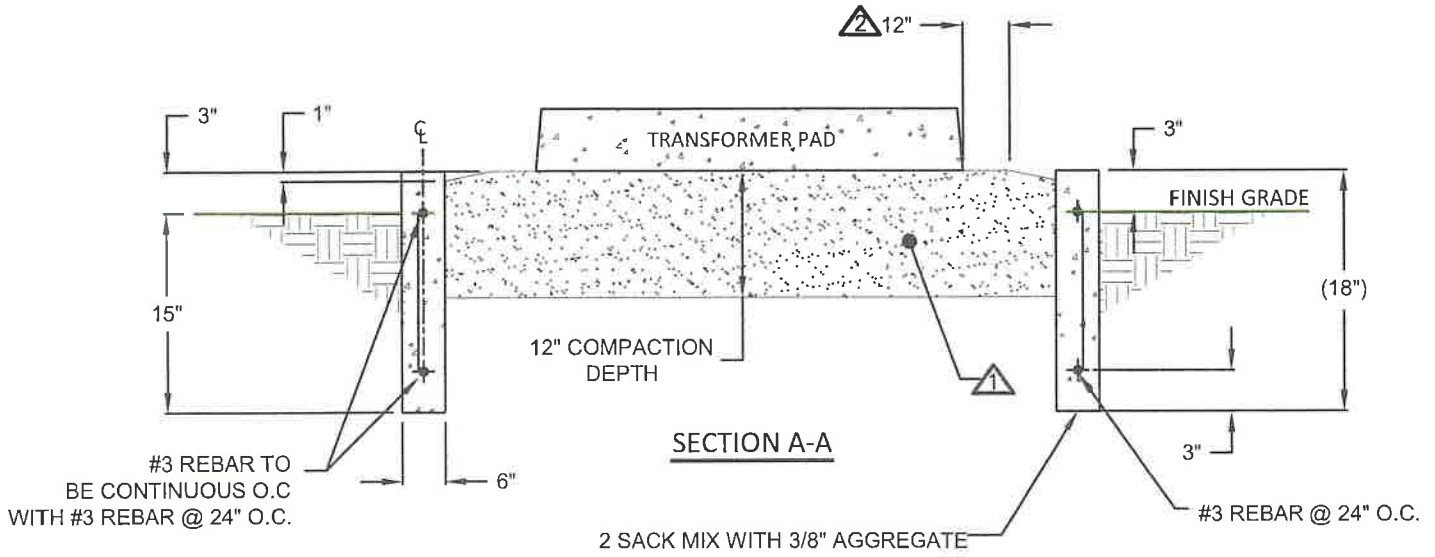

NOTES:

▲ COMPACTED AREA SHALL BE CALTRANS CLASS 2 AGGREGATE BASE OR CRUSHER FINES WITH 3/8" ROCKS.
SECTION 5.5 COMPACTION PROCESS.

▲ A MAXIMUM OF 1/2" OF SAND FILL WILL BE APPROVED FOR LEVELING OF COMPACTION AREA.
SECTION 5.5 COMPACTION PROCESS.

SP/NOTIFICATION # 4029692
SERVICE ORDER # 60126554
SHEET 23 OF 27

DRAWN BY		IMPERIAL IRRIGATION DISTRICT	
DRAWN BY	<i>JR</i>	 100.9	TRANSFORMER PAD CONCRETE RE-ENFORCEMENT CURB DETAIL
REVIEWED	<i>MB</i>		
APPROVED	<i>MB</i>		
REVISION	REV 3		
DATE	9-27-2016		

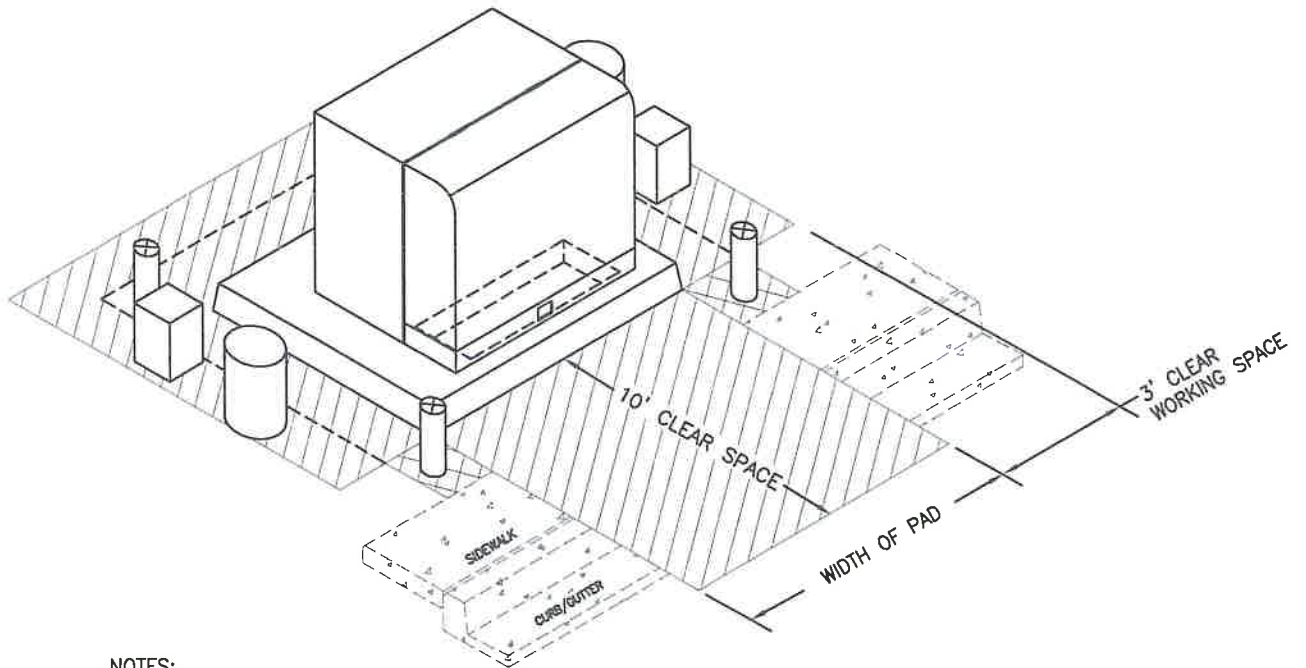

NOTES:

- ⚠ THE PURPOSE OF THIS DRAWING IS TO ILLUSTRATE THE REQUIRED CLEARANCES FROM AN I.I.D TRANSFORMER TO OTHER UTILITIES (18") AND MINIMUM HOT STICK CLEARANCE.
- ⚠ WHEN BARRIER POSTS ARE REQUIRED, ALL OTHER UTILITIES TO STAY CLEAR OF AREA. (REFER TO BARRIER POST DETAIL, 181.6, SECTION 5.32.)

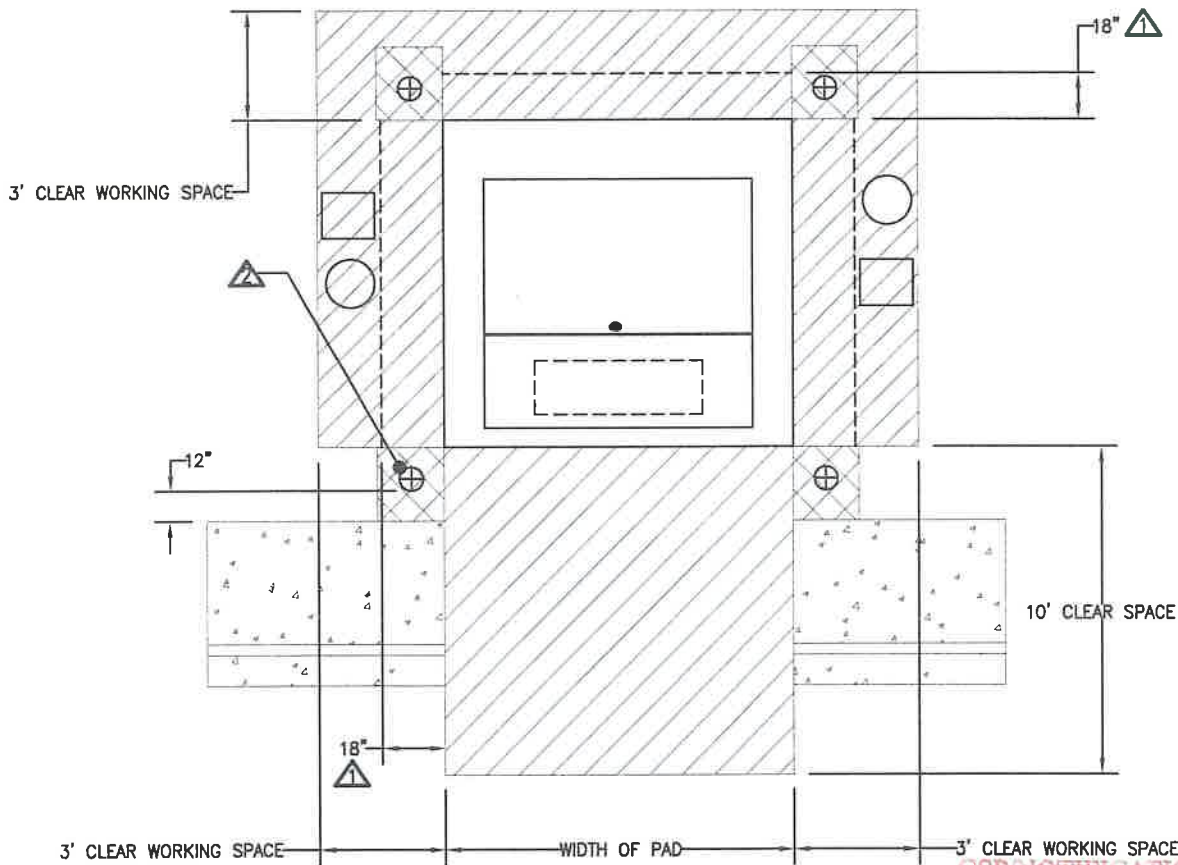

CSP/NOTIFICATION # 4029692
 24
 60126554
 27

IMPERIAL IRRIGATION DISTRICT		 PRECAST TRANSFORMER PAD SPATIAL CLEARANCES WITH COMMUNICATION
DRAWN BY	<i>gr</i>	
REVIEWED	<i>[Signature]</i>	
APPROVED	<i>MB</i>	
REVISION	REV 2	
DATE	9-29-2016	202.5

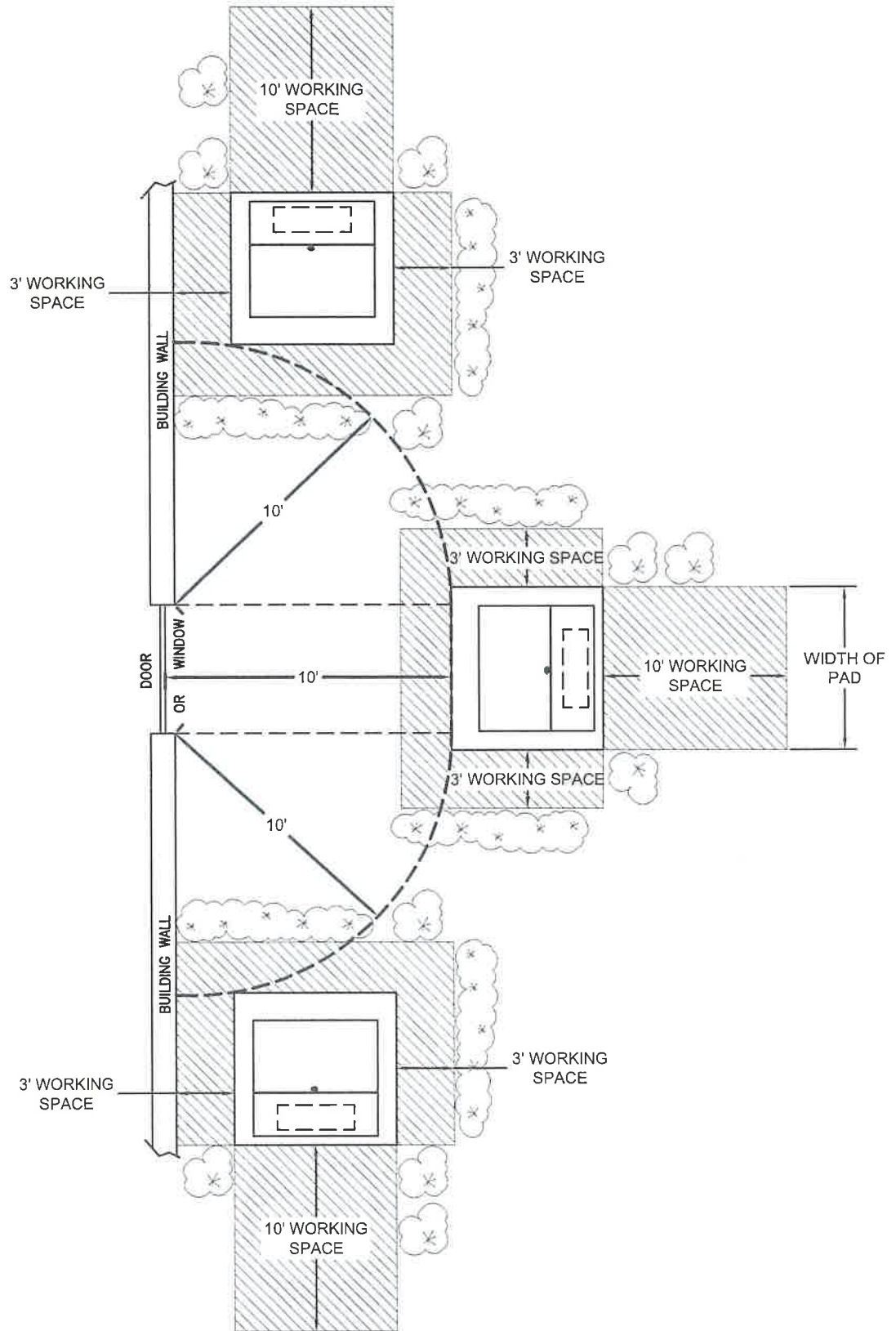

NOTES:

- 1. NO WINDOW OR DOOR SHALL BE WITHIN A 10' (120") RADIUS OF OIL FILLED EQUIPMENT.

CSP/NOTIFICATION # 4029692
 SER** 60126554
 SHE. 25 27

IMPERIAL IRRIGATION DISTRICT			IID EQUIPMENT CLEARANCE
DRAWN BY	<i>jk</i>		
REVIEWED	<i>ms</i>		
APPROVED	<i>ms</i>		
REVISION	REV 6		
DATE	12-09-2013	100.16	

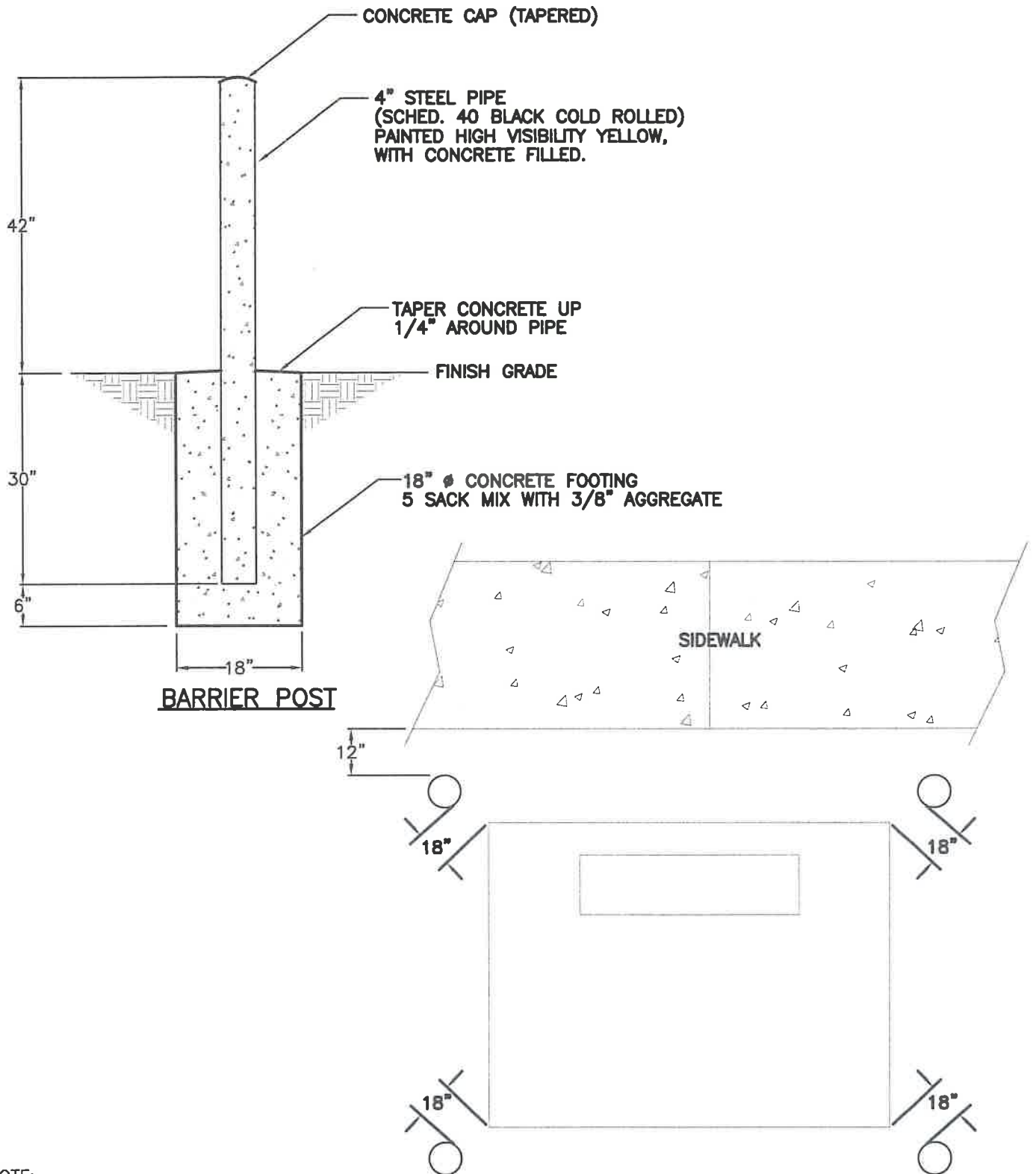

NOTE:

1. REMOVABLE BARRIER POSTS ARE NOT ALLOWED.
2. IMPERIAL VALLEY TRANSFORMER PAD SHOWN.

CSP/NOTIFICATION # 4029692
 SERVICE ORDER # 60126554
 SHEET 26 OF 27

DRAWN BY		IMPERIAL IRRIGATION DISTRICT	
REVIEWED	<i>[Signature]</i>		TYPICAL BARRIER POST DETAIL
APPROVED	<i>[Signature]</i>		
REVISION	REV 5		
DATE	9-27-2016		
		181.6	

- 6.23 Any IID underground high voltage structure i.e., transformer, switch, sector, capacitor bank, and secondary voltage metering equipment shall maintain a 10 foot (120") radial clearance from any commercial propane tank, vent, or fill-tube that contains flammable liquids, gases, vapors, or mixtures. Refer to NFPA 58 Sections 6.3, Containers Separation Distances.

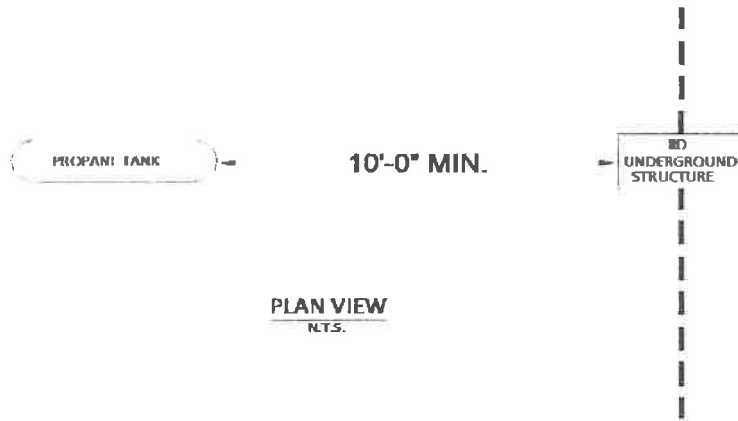

CSP/NOTIFICATION # 4029692
SERVICES # 60126554
SHEET 27 OF 27